



Loading technology

Energy-efficient complete solutions for quick and safe operations

HÖRMANN





- 4 Hörmann brand quality
- 6 Sustainably produced
- 7 Simple and sustainable planning

- 8 Good reasons to try Hörmann
- 12 Proper planning
- 14 Dock levellers
- 16 Mechanical dock levellers
- 18 Hydraulic dock levellers
- 24 Working ranges, dimensions
- 26 Controls
- 29 Special control construction
- 30 Fitting variants
- 34 Dock levellers for special requirements
- 37 Dock levellers with integrated RFID technology
- 38 DOBO system
- 42 Loading houses
- 48 Dock shelters and seals
- 64 Buffers, fitting plates and support brackets
- 72 Safety, protection and comfort equipment

- 78 Hörmann product range

Hörmann brand quality

Reliable and oriented towards the future



Obeta central warehouse in Ludwigsfelde with Hörmann products

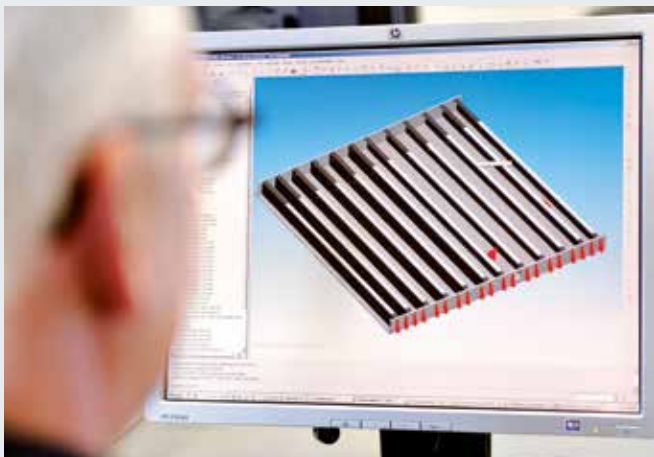

In-house product development

At Hörmann, innovation is produced in-house – highly qualified employees of the development department are in charge of product optimisation and new developments. This results in market-ready, high-quality products that are very popular around the globe.

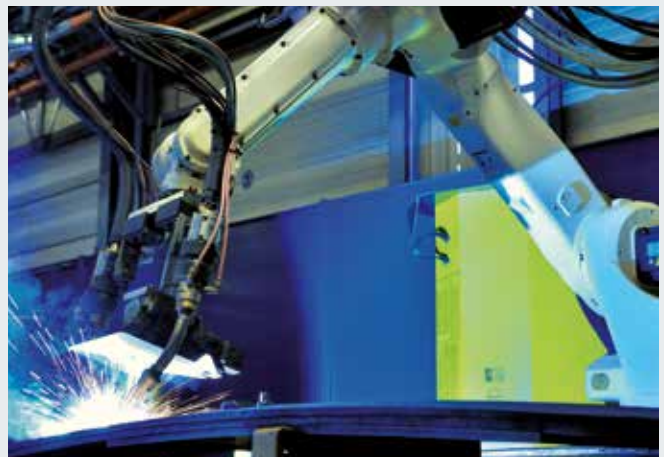

Modern manufacturing

Hörmann's high automation level ensures a consistently high quality level. All production processes are precisely calibrated and monitored by modern computer systems. This way, large quantities of dock levellers, shelters and seals are manufactured, all with equal precision. However, we also manufacture smaller quantities or customised special solutions according to customer specifications at the same high quality level.



As Europe's leading manufacturer of doors, door frames, operators and loading technology we are committed to high product and service quality. This is how we set standards on an international scale.

Highly-specialised factories develop and manufacture construction components that are marked by excellent quality, functional safety and a long service life.

Our presence in the global economy's regions makes us a strong, future-oriented partner for industrial and public construction projects.



Competent advice

Experienced specialists within our customer-oriented sales organisation accompany you from the planning stage, through technical clarification up to the final building inspection. Complete working documentation, such as, e.g. technical manuals, is not only available in printed form, but also always accessible and up-to-date at www.hoermann.com



Fast service

Our extensive service network means that we are always nearby and at your service around the clock. This is a great advantage for testing, maintenance and repairs.



Documented and approved by the ift in Rosenheim

Hörmann received confirmation of sustainability through an environmental product declaration (EPD)* in accordance with ISO 14025 from the Institut für Fenstertechnik (ift – Institute of window technology) in Rosenheim. The inspection was based on the Product Category Rules (PCR) Loading Systems from ift Rosenheim GmbH, issue PCR-VS-1.1: 2011. Environmentally-friendly production was confirmed by a life-cycle analysis in accordance with DIN ISO 14040 / 14044.

Sustainably produced loading technology from Hörmann

- Ecological quality**
Environmentally-friendly production through a comprehensive environmental and energy management system
- Economical quality**
A long service life and low maintenance costs thanks to the use of high-quality materials
- Process quality**
Sustainable production processes through optimised material use

Sustainable construction with Hörmann's expertise

Hörmann has been able to gain great expertise in sustainable construction through various projects. We also apply this know-how to support your projects.



* The Environmental Product Declaration (EPD) can be found on the Internet at www.hoermann.de/dokumentationen

Simple and sustainable planning

With the Hörmann Architects' Program and energy savings compass



The Architects' Program

More than 9000 drawings for over 850 products

Planning with Hörmann products is now even easier thanks to a modern, user-friendly interface. Clearly structured navigation via drop-down menus and symbols, as well as a search function, provide faster access to texts for invitation of tenders and drawings (in DWG and PDF format) of over 850 Hörmann products. **In addition, BIM data can be provided for many products for the Building Information Modelling process, enabling efficient planning, drafting, construction and management of buildings.** Photos and photo-realistic presentations provide additional information on many products.



The Architects' Program is available to you as a web version at www.hormann.co.uk/forums/architects-forum/architects-program or can be downloaded free-of-charge from the Hörmann Architects' Forum.

The energy savings compass for sustainable planning

Hörmann's energy savings compass shows how industrial door systems and loading technology are planned with energy-efficiency and sustainability in mind. An integrated calculation module estimates the amortisation period for door and loading technology systems.

The energy savings compass is available as a web-based interface for PC / MAC and mobile end devices.



Plan with the energy savings compass at:
https://www.hormann.co.uk/fileadmin/_country/UK/Energiesparkompass/Energy_savings_compass/ml_eskSCALEframe.html



We are a member of the professional association for digital building products in the Federal Association of Building Systems e.V.

Good reasons to try Hörmann

Convincing solutions from the market leader for doors and loading technology



1

Intelligent details for optimum connection

Reliable anchoring of Hörmann dock levellers in the building structure is a basic requirement for lasting function. Intelligent fitting details support fitting by casting up to a **casting height of 250 mm**: with **screw-in adjustment angles**, the dock leveller can be easily levelled. **Particularly stable flat anchors** enable a permanently stable connection. **Ventilation slots in the edge bracket** reliably prevent weak points in the building connection, since the air can escape when compacting the concrete.

For further information, see pages 32 – 33.

2

Long service life and soft transitions

High loading forces occur at dock levellers, especially at the rear in the hinge area. For safe and long-lasting operation, the connection to the building structure must be carried out perfectly. With **Hörmann pit models** with anchor brackets on the rear, notches indicate exactly the position and length of the **optimum weld seam**. The recess also ensures a flat surface and a smooth transition from the building floor when driving on the dock leveller. Depending on the version, the anchor bracket on the rear is supplied as standard or can be selected.

For further information, see pages 30 – 31.



3

Building protection using steel buffers with absorption

The forces that arise during docking can be huge. Steel buffers are much more resistant to wear and damage than rubber buffers. However, good absorption is also important, otherwise the building structure will be overloaded or the docking lorry damaged. Hörmann steel buffers SB 15 and SB 20 offer a **good balance of long service life and absorption**. Behind the 12-mm-thick steel plate, a special 8-chamber rubber buffer completely absorbs the docking forces and protects the building structure and vehicle.

For further information, see page 67.

4

Certified construction and lean design

Hörmann loading houses meet all requirements regarding stability and safety with their narrow design. The LHP 2 version with double-skinned panels is suitable as standard for **roof loads up to 3 kN/m²**. The frame construction is dimensioned according to **Eurocode “Basis of structural design”** as well as **Eurocode 1 and 3** and **certified according to EN 1090**. As a structure, loading houses fall under the scope of the Construction Products Regulation. With standard-compliant components, CE label and online declaration of performance, **CE conformity** can be verified at any time.

For further information, see pages 44 – 45.

Good reasons to try Hörmann

Individual solutions from the market leader for doors and loading technology

 Only from Hörmann



5

Sustainable loading with DOBO systems

With Hörmann **DOBO docking systems (docking before opening)**, the hall door and vehicle doors are **only opened when it is really necessary**. The lorry docks with closed vehicle doors. From the docking assistant, the dock shelter, and the dock leveller to the movable buffers, all components are optimally matched to each other. The DOBO system ensures **hygienic transport and closed cold chains**, reduces energy costs, prevents break-ins and offers advantages in customs clearance. DOBO systems can be implemented particularly easily with loading houses.

For further information, see pages 38 – 41.



6

Extra height clearance for docked lorries

Telescopic link arms offer the flap dock shelters an extra height clearance. These **patented optional extras** allow the entire front frame to move upwards. This is necessary if swap trailers lift during parking or if vehicles are raised when docking and then spring up during unloading. **This prevents damages to the dock shelter**, especially at the top edge. These optional extras can also be retrofitted on existing dock shelters.

For further information, see pages 50 – 51.



7

Special solutions for parcel services and transit vans

The cushion dock seal BBS has been specially developed for small transport vehicles, e.g. for parcel delivery services. It consists of three foam-filled cushions, which ensure optimum sealing between the vehicle and the loading bay. The design has been optimised for Mercedes Sprinters and VW Crafters with high roof. The conical shape of the black cushions was adapted exactly to their shape, so that it fits the rear contours of the most common transit vans without creating a gap. The seal is also guaranteed for hinged doors with an opening angle of 180 and 270 degrees. Upon request, we also develop and manufacture further tailor-made solutions for other vehicle types.

For further information, see from page 62.

8

Easy installation with combination control

Hörmann controls for industrial doors and dock levellers **can be combined very well due to standardised housing sizes and the same cable sets**. It is even easier to install a **combination control 420 Si for hinged lip dock levellers or 420 Ti for telescopic lip dock levellers**, as the door operation is already integrated. This means you can operate the dock leveller and the door operator WA 300 S4 for sectional doors or WA 300 R S4 for rolling shutters with only a compact control.

For further information, see from page 26.

Proper planning

Sustainability begins with planning

Loading technology inside the building

For interior solutions, the door usually closes on the dock leveller, so that in temperature-controlled buildings unnecessary energy losses through the dock leveller are prevented. Hörmann concepts with a door running in front of the dock leveller and an insulated panel under the dock leveller offer the following advantages:

- **Improved thermal insulation:** The heat loss outside of the loading time is minimised.
- **Protection against weather conditions:** warehouse staff are well protected behind the door.

Dock levellers in the building require:

- Correctly dimensioned and equipped **fitting pits**
- A reliable **building connection in the concrete**



Loading technology in front of the building

The exterior solution, in which the dock leveller is placed in front of the building in a loading house, impresses with the following advantages:

- **Optimal thermal insulation:** The door closes the building and minimises energy loss, especially when loading is not taking place.
- **Maximum utilised space:** The building can be fully used up to the door.
- **Simple modernisation:** A complete loading bay can be added to the building without costly reconstruction measures.

Loading houses require:

- **Space in front of the building:** Loading houses limit the manoeuvring space in front of the building. An angled arrangement can increase the space.
- **Protection against weather conditions:** We recommend galvanized dock levellers in outdoor areas.





Dock levellers

Product and planning advantages

Fast loading and unloading

Efficient loading is only possible when the load is moved in or out of the lorry in a single horizontal movement. Hörmann dock levellers with particularly flat transitions are the ideal solution to compensate for the difference in height between different lorry loading surfaces and the loading platform.



Optimal loading platforms

Your vehicle fleet is crucial for planning the right loading platform. Select the ramp height so that the height difference to the lorry loading surface is as small as possible. You should also consider the vertical movement of the vehicle e.g. due to the spring deflection during loading and unloading or the parking heights for swap trailers.



Efficient loading concepts

Energy-saving loading concepts, e.g. with a thermally insulated door running in front of the dock leveller, improve the insulation especially outside the loading times. The DOBO system not only facilitates the docking of the lorry, but also allows closed cold chains, since the lorry doors are opened only after docking.



Application areas

The right dock leveller for any requirement

At approximately the same loading heights and low height difference to the building floor

- Mechanical dock levellers MLS
- Mechanical loading platforms MRS

For further information, see pages 16 – 17.



For larger height differences, larger distances and as a base frame for loading houses

- Hydraulic dock levellers HLS, HLS 2, HTL 2
- Hydraulic loading platforms HRS, HRT

For further information, see pages 18 – 25.



For different vehicle types on a loading platform

- Hydraulic dock leveller HTLV 3 for lorries and transit vans
- Hydraulic dock leveller and scissors lift table lift leveller for loading at ramp level as well as for lifting and lowering of goods

For further information, see pages 34 – 36.



Mechanical dock levellers

With uniform fleet and low height difference to the building floor

1 Flexible dock leveller platform

The platform is made of moulded, slip-resistant steel S 235 (6 / 8 mm thick).

2 Robust self-cleaning hinged lip

The hinged lip supplied is made of moulded, slip-resistant steel S 355 JO (12 / 14 mm thick). The closely spaced hinge strips (32 units on a 2 m wide dock leveller) enable improved force distribution in comparison to hinge bushings. The open design prevents the collection of dirt in the hinge. The angle of the lip allows a convenient support on the loading surface.

3 overall construction resistant to working stresses

As is the case with hydraulic dock levellers, the self-supporting steel joint construction is resistant to working stresses up to 60 kN as standard (rated load according to EN 1398). Particularly narrow versions up to 1500 mm can be loaded with max. 45 kN.

4 Simple operation

The platform is raised using the control bar. The hinged lip folds out in an opposing movement and is positioned on the loading surface. The force is within the limits set by EN 1398.

5 Gas spring support

The gas spring ensures counterbalance and facilitates the operation.

6 Corrosion protection

The steel surfaces are sandblasted and supplied in 2C PU-coated Traffic black RAL 9017. Upon request, the surface is also available in Ultramarine blue RAL 5002, RAL to choose or galvanized. The support brackets on the MRS dock leveller are generally galvanized.

Tip: We generally recommend the galvanized version for dock levellers in outdoor areas.

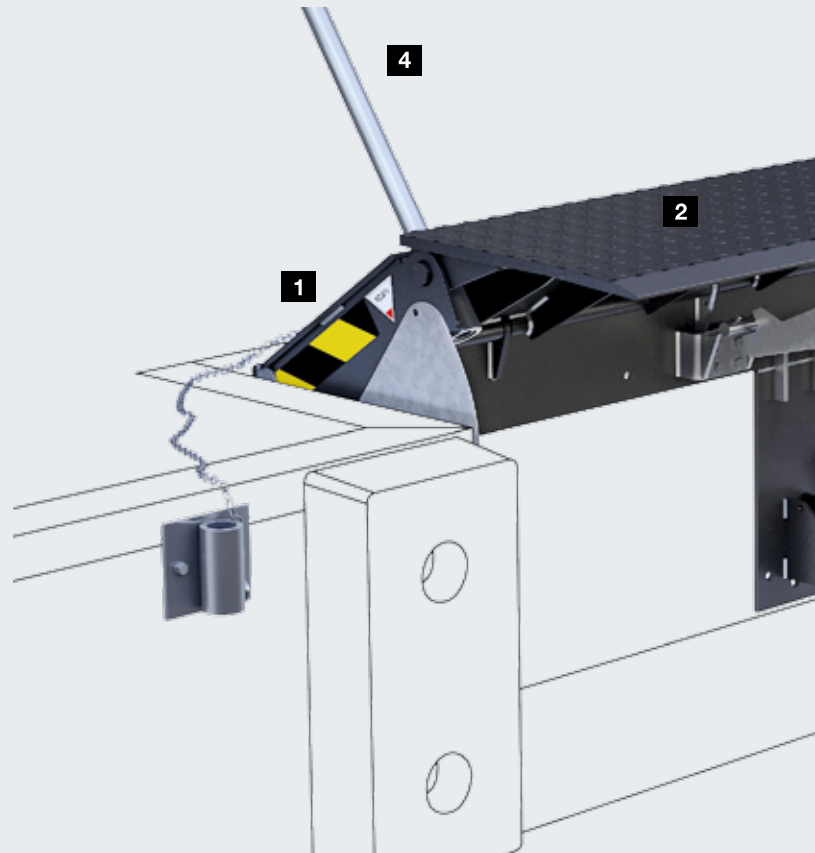

Mechanical dock leveller MLS in Traffic black RAL 9017

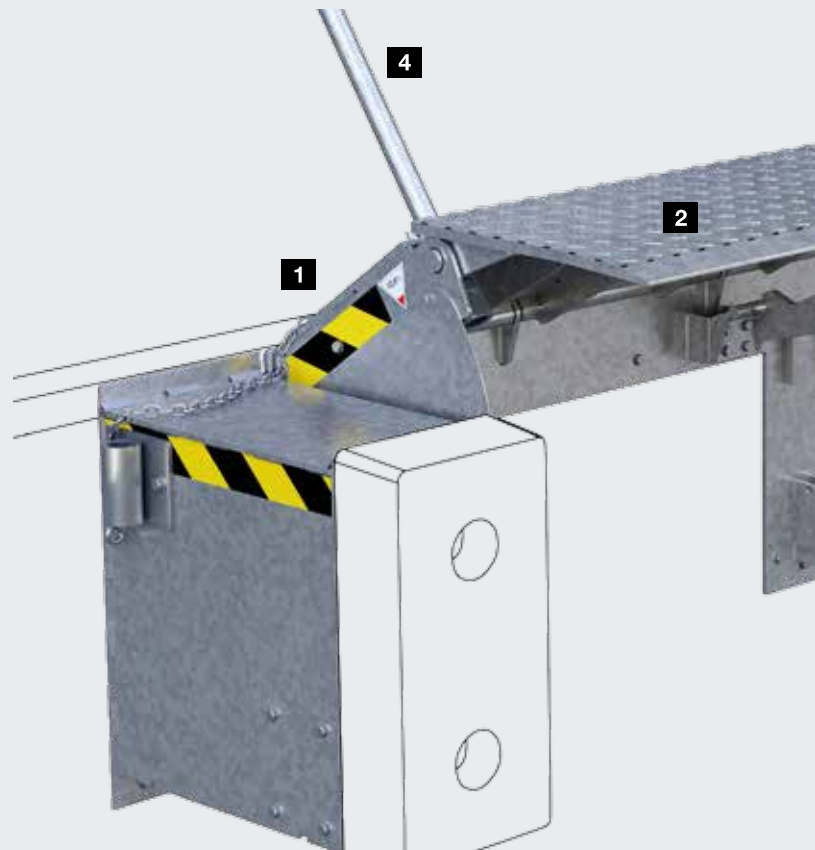

Mechanical dock leveller MRS-V in galvanized version

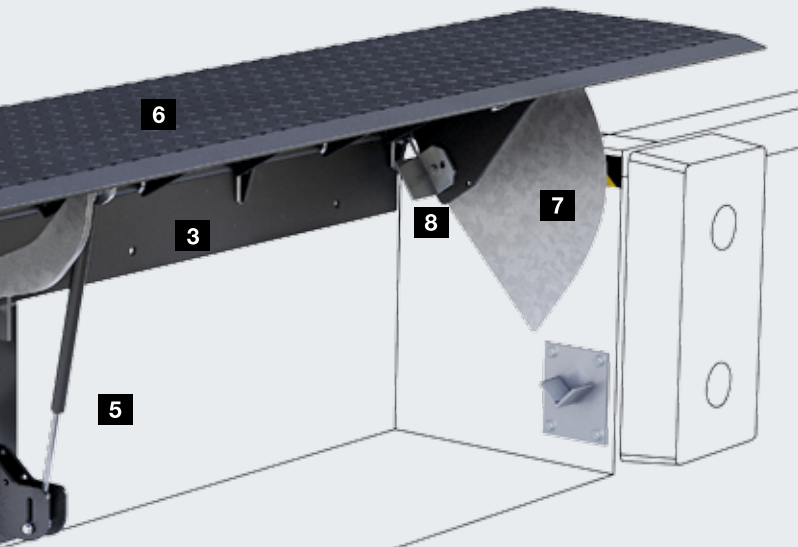

Tip: Protect the ramp and vehicles with buffers, preferably type DB15 or DB15 PU with a depth of 100 mm. Ensure a sufficient support depth (at least 100 mm) on the loading surface.

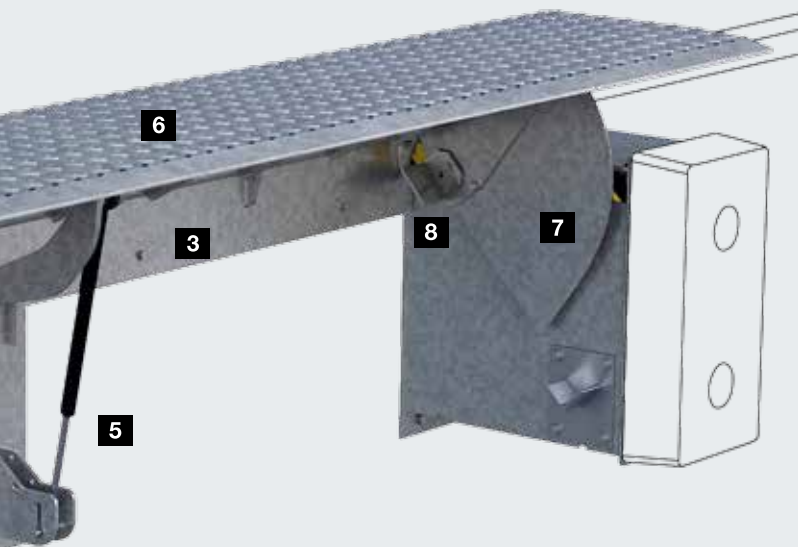

Tip: For MRS dock ramps, use a flap dock shelter e.g. DSS, with at least 900 mm depth to bridge the fitting depth of the side brackets and buffers.

Reliability through safety components

7 Foot guard plates

Side sheets prevent the foot from becoming trapped between the loading platform and dock leveller.

Anti-slip profiling

Upon request, the platform and lip are additionally equipped with anti-slip coating in class R11 according to DIN 51130 made of Twaron fibre-reinforced polyurethane, if necessary also with sound-absorbing features.

Safety marking

The black-yellow marking indicates the working position.

8 Maintenance supports

They allow the safe performance of maintenance work.

Simple, safe and reliable to fit

- Supplied including lifting equipment for fork-lifts
- MLS: fitting by welding in a prepared pit. Alternatively with casting box: self-supporting base frame, closed on three sides, provided with edge brackets and anchors for fitting by casting in an on-site timber mould.
- MRS: fitting by welding in front of the loading platform. Side support brackets, either vertical (MRS-V) or horizontal (MRS-H), with screw-in sleeves for easy buffer fitting

Working range and dimensions

	MLS, MRS				
Working range	At max. 12.5 % slope according to EN 1398: above level 68 mm, below level 106 mm				
Ordering widths (mm)	1250	1500	1750	2000	2250
Overall length dock leveller (mm)	Approx. 735				
Positioning (mm)	Approx. 150				
Depth of support brackets	Type MRS: 435 mm without buffers				

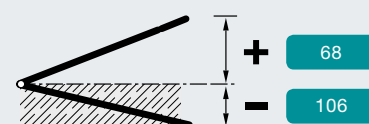

All dimensions in mm

Hydraulic dock levellers

With changing vehicles and larger height differences to the building floor

1 Flexible, load-bearing platform

- The S 235 moulded steel platform is made of a single piece up to a size of 2000 × 3000 mm. With wider and longer dock levellers, a carefully made weld seam joins the plates, resulting in a continuously sturdy platform.
- Precise profile dimensioning on the bottom platform edge and dual cylinder hydraulics enable an extremely high capacity for torsion without sacrificing stability. This allows the dock leveller to move along with the lorry loading surface, even with asymmetrical side inclinations. The number and design of the girders prevent deformation (track groves) beyond the degree required by EN 1398.
- The platform on hinged lip dock levellers is 6 / 8 mm thick as standard, 8 / 10 mm thick on telescopic lip dock levellers. On request, a 8 / 10-mm-thick platform is also available for hinged lip dock levellers e.g. to avoid deformation when reach trucks regularly roll over the platform.

2 Sturdy lip

- The hinged lip and telescopic lip are made of running plate from a single piece.
- The lip made of moulded steel S 355 JO fulfils all requirements with a thickness of 12 / 14 mm.

3 overall construction resistant to working stresses

- The dock leveller can be loaded as standard up to 60 kN, optionally up to 90 kN (rated load according to EN 1398). For particularly heavy goods, the hinged lip dock leveller can also be supplied for rated loads up to 180 kN.
- The dock leveller is designed for a temperature range of -10 to +50°C in the area of the hydraulic system, i.e. below the dock leveller. The use of special oils makes sense at low temperatures.

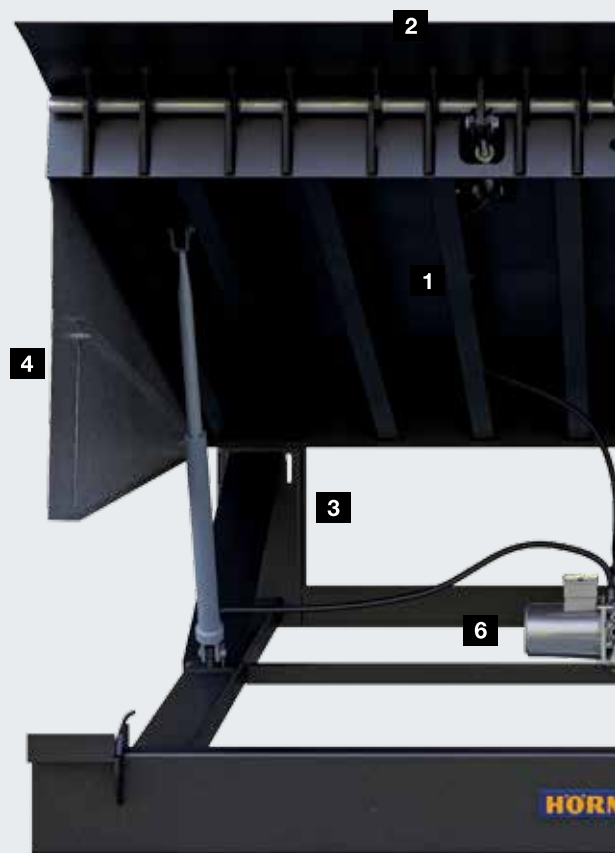

Hinged lip dock leveller, type HLS 2 pit model P for fitting by welding

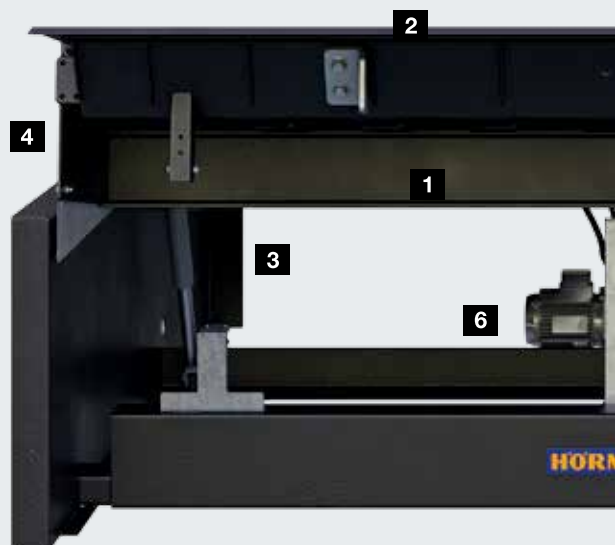

Telescopic lip dock leveller, type HTL 2 frame model FR with self-supporting base frame for fitting by casting



Reliability through safety components and double cylinder hydraulics

4 Foot guard plates

Side sheets prevent the foot from becoming trapped between the ramp and dock leveller.

Anti-slip profiling

Upon request, the platform and lip are additionally equipped with anti-slip coating in class R11 according to DIN 51130 made of Twaron fibre-reinforced polyurethane, if necessary also with sound-absorbing features.

Safety marking

The black-yellow marking indicates the working position.

5 Maintenance supports

They allow the safe performance of maintenance work.

6 Reliable double cylinder hydraulic system

2 main cylinders ensure the balanced, reliable and, most importantly, safe operation of the dock leveller at all times. In case of an emergency stop, e.g. when the lip is no longer supported by rolling away of the lorry, the automatic emergency stop valves of both cylinders react almost simultaneously. As a result, the platform is prevented from tilting during an emergency stop.

On request, dock levellers HLS 2 and HTL 2 can be equipped with an oil drain pan.

Hydraulic dock levellers with hinged lip

For simple bridging and for rated loads of up to 180 kN

Robust hinged lip

The closely spaced hinge strips **1** (32 units on a 2 m wide dock leveller) on one axle (28 mm diameter) enable better force distribution in comparison to hinge bushings. The open design prevents the collection of dirt in the hinge e.g. wood chips.

Simple operation at the press of a button **2** **3**

The electronic hydraulic system moves the platform to the highest position and then automatically extends the hinged lip. The platform is then lowered until the hinged lip is placed on the loading surface. Now the lorry can be quickly and safely loaded and unloaded. The angle of the lip allows a convenient support on the loading surface. The platform and lip are edge to edge **3**. The front edge offers a flat transition to the loading surface due to the particularly angled milling. This makes hinged lip dock levellers a good choice for sensitive goods.

Available versions

Dock leveller HLS

The efficient solution

- Up to 3 m length
- Up to 60 kN rated load acc. to EN 1398
- Installation model for fitting by welding

Dock leveller HLS 2

Versatile construction

- Up to 5 m length
- Optionally up to 180 kN rated load acc. to EN 1398
- Pit model for fitting by welding
- Frame model for casting in concrete
- Frame model for fitting by welding in a preassembled frame

HRS loading platform

The dock leveller pedestal combination as a base frame for a dock leveller

- Up to 3 m length
- Up to 60 kN rated load acc. to EN 1398

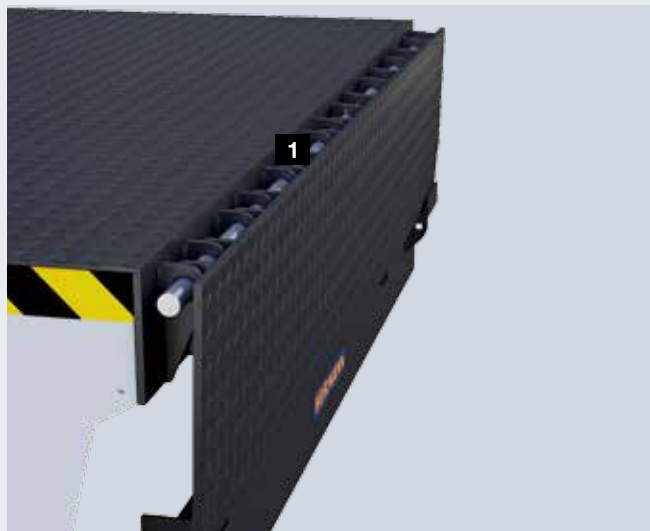

Take a look at the video "Hinged lip dock leveller" at: www.hoermann.com/mediacenter

Hydraulic dock levellers with telescopic lip

For energy-saving loading concepts and precise bridging



Stable, continuously extendable telescopic lip

The telescopic lip with a robust front lip is reinforced throughout. The overlap limiters on the bottom side of the telescopic lip prevent incorrect loading due to a positioning that is too low.

1 Sound-absorbing pedestal

When steel comes into contact with steel, this generates noise that is neither pleasant nor healthy for employees. The rubber buffers on the pedestal of the telescopic lip dock leveller absorb the contact noise when positioning the platform.

Simple operation for precise positioning

The telescopic lip can be extended and retracted in a targeted manner via separate control buttons, and can be placed precisely and controlled on the loading surface. The continuous and precise extending and lowering of the telescopic lip allows simple and safe unloading of even fully loaded lorries. This way, even pallets that are situated at the end of the vehicle's loading surface and thus only provide limited telescopic lip space, can be loaded. Notches on the outside **2** indicate the correct contact area on the loading surface (100 – 150 mm). The lip is slightly tilted to guarantee favourable contact with the loading surface. Flat transitions from the platform to the lip and to the loading surface ensure safe loading **3**.



Available versions

Dock leveller HTL 2

The flexible construction

- Up to 5 m length
- Optionally up to 90 kN rated load acc. to EN 1398
- Pit model for fitting by welding
- Frame model for casting in concrete
- Frame model for fitting by welding in a preassembled frame

Loading platform HRT

The dock leveller pedestal combination as a base frame for a dock leveller

- Up to 3 m length
- Up to 60 kN rated load acc. to EN 1398



Take a look at the video "Optimally matched system" at: www.hoermann.com/mediacenter

Hydraulic dock levellers

Additional optional equipment

Surface finishes

Standard

The steel surfaces are sandblasted and 2C PU-coated in-house. We supply the dock leveller in Traffic black RAL 9017 **1**

On request

The coating is optionally available in Ultramarine blue RAL 5002 or in RAL to choose, to match the overall colour design.



For higher corrosion protection

For increased corrosion protection requirements, we recommend the galvanized version **2**.

Tip: For outdoor use, always choose the galvanized version.

For increased anti-slip requirements

An anti-slip coating of class R11 according to DIN 51130 is recommended e.g. in case of increased moisture due to cleaning in meat processing plants. The coating is applied to the moulded material of platform and lip. This way, the anti-slip requirements of EN 1398 are complied with even in case of damage.

For improved sound insulation **3**

In order to significantly reduce the noise when driving over the dock leveller, a thicker anti-slip coating is applied. This reduces contact noise and thus creates a pleasant work environment. The sound emissions depend on the tyre type and speed of the transport vehicles as well as on any inherent sound of the transported goods.



Gap sealing

For dock levellers that are fitted inside the building, gap sealing is strongly recommended. When the dock leveller is in the home position and at low inclination also in working position, the side gap next to the dock leveller is sealed. It prevents drafts as well as the escape of warm air.



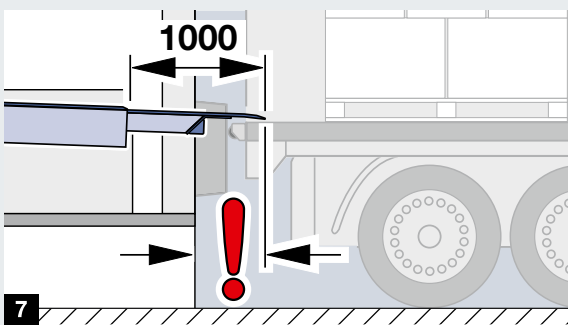
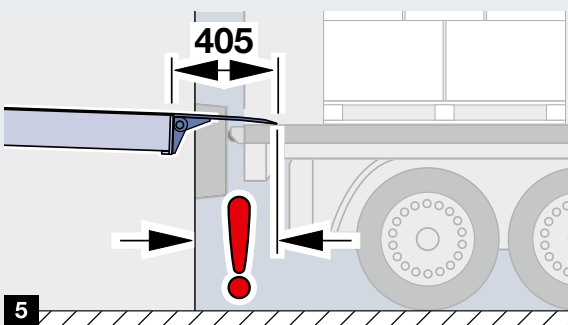
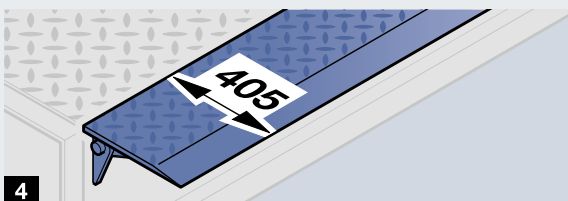
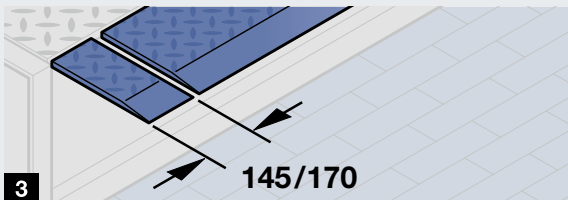
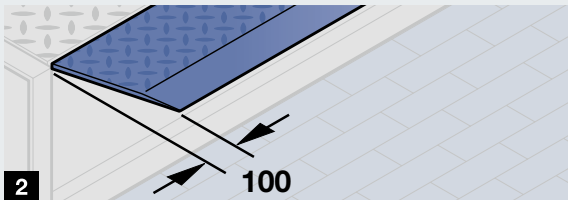

Lip shapes

1 Type R, straight

Standard up to 2000 mm ordering width, optionally over 2000 mm

2 Type S, angled

Standard over 2000 mm ordering width, optionally up to 2000 mm

3 Type SG

With separate lip segments to accommodate various lorry widths, resistant to working stresses up to 600 kg. Folding out or sliding out of the segments stops when they encounter an obstacle, e.g. the lorry. Folding in or sliding in takes place automatically when returning to the home position. Exclusively available for type HLS 2, HRT and HTL 2 with rated load up to 60 kN.

- For hinged lips approx. 145 mm wide
- For telescopic lips approx. 170 mm wide

Lip lengths

Select a lip length so that a contact surface of at least 100 mm in accordance with EN 1398 and maximum 150 mm is possible. Note the distance from the lorry to the ramp using buffers on the ramp and vehicle.

Hinged lip dock leveller

The lip has a standard length of 405 mm **4**, on request also 500 mm. When selecting, please note that the protruding lip hinge reduces the possible levelling **5**. Request detailed information and seek consultation!

Telescopic lip dock leveller

As standard, the telescopic lip is supplied in a length of 500 mm **6**. Some applications, particularly when the building door is positioned in front of the dock leveller, require a longer lip. For such cases, the telescopic lip lengths 1000 mm and 1200 mm **7** are available.

Hydraulic dock levellers with hinged lip

Working ranges, dimensions

HLS 2 With hinged lip

HLS / HRS With hinged lip

The values indicate the difference in height, which, taking into account the maximum gradient / inclination according to EN 1398, can be bridged by a maximum of 12.5 %. The technically possible range is considerably larger depending on the dock leveller length. Note that these are limit values. Preferably select the next higher length size.

Plan the ramp height so that the height difference to the lorry loading surface is as small as possible!

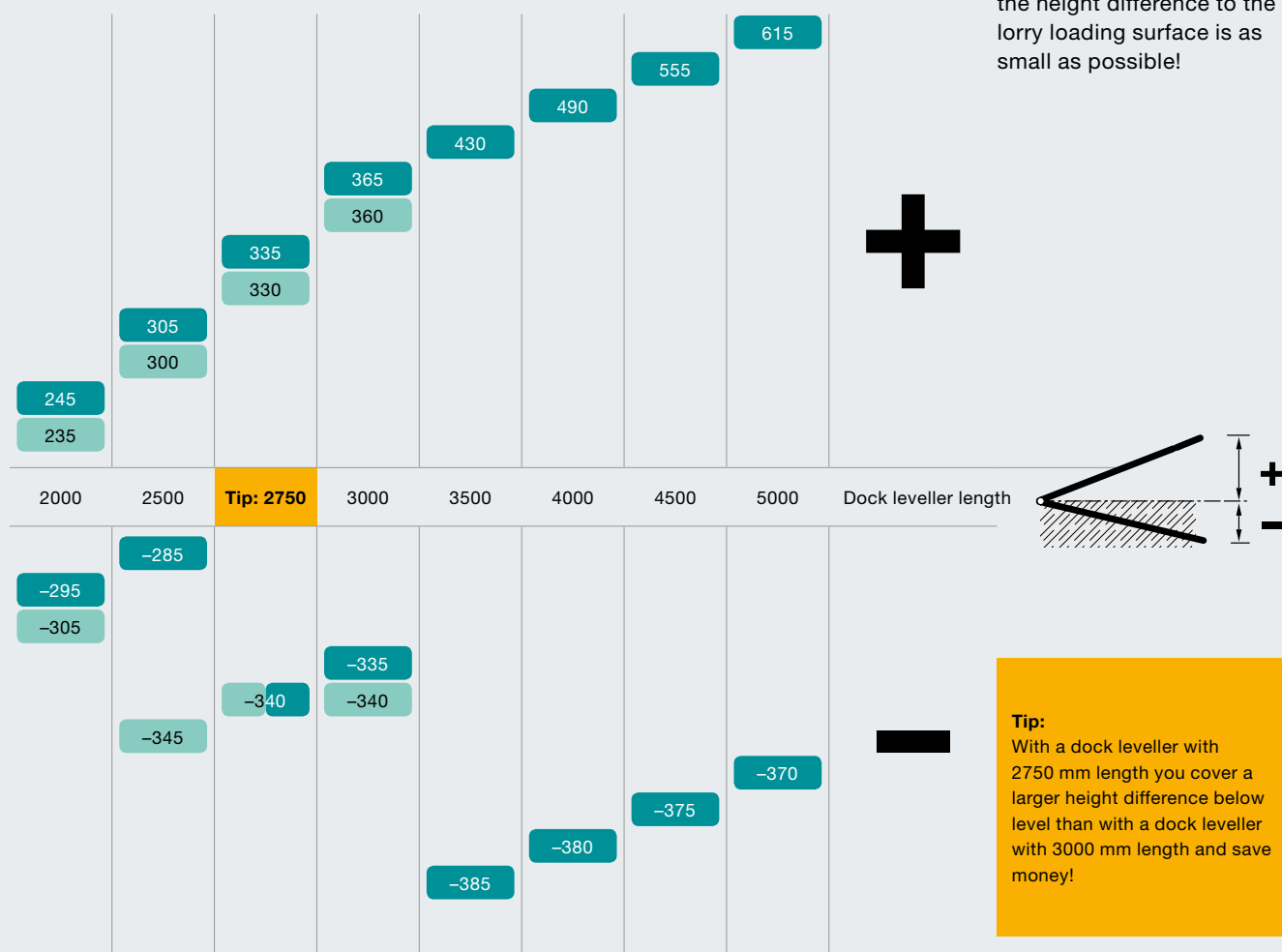

Dimensions

Ordering length	2000 2500 2750 3000 3500 4000 4500 5000									Ordering width
Dock leveller										Dock leveller
Height	HLS	650	650	650	650					2000, 2100, 2250
	HLS 2	595	595	645	645	745	745	745	745	
Ramp height	HRS	875 – 1360								2000, 2100, 2250 overall width 3500 mm

All dimensions in mm

Hydraulic dock levellers with telescopic lip

Working ranges, dimensions

- With telescopic lip 1200 mm
- With telescopic lip 1000 mm
- With telescopic lip 500 mm

The table indicates the maximum working range (limit value range) when the lip is extended completely.

Choose the length of the dock leveller to match the working area, but the length of the lip to match the required bridging. The larger working range should not be a reason to choose a longer lip. This effect can only be achieved if the distance to the ramp is also increased. In this case, check for possible further effects of this measure or let us advise you.

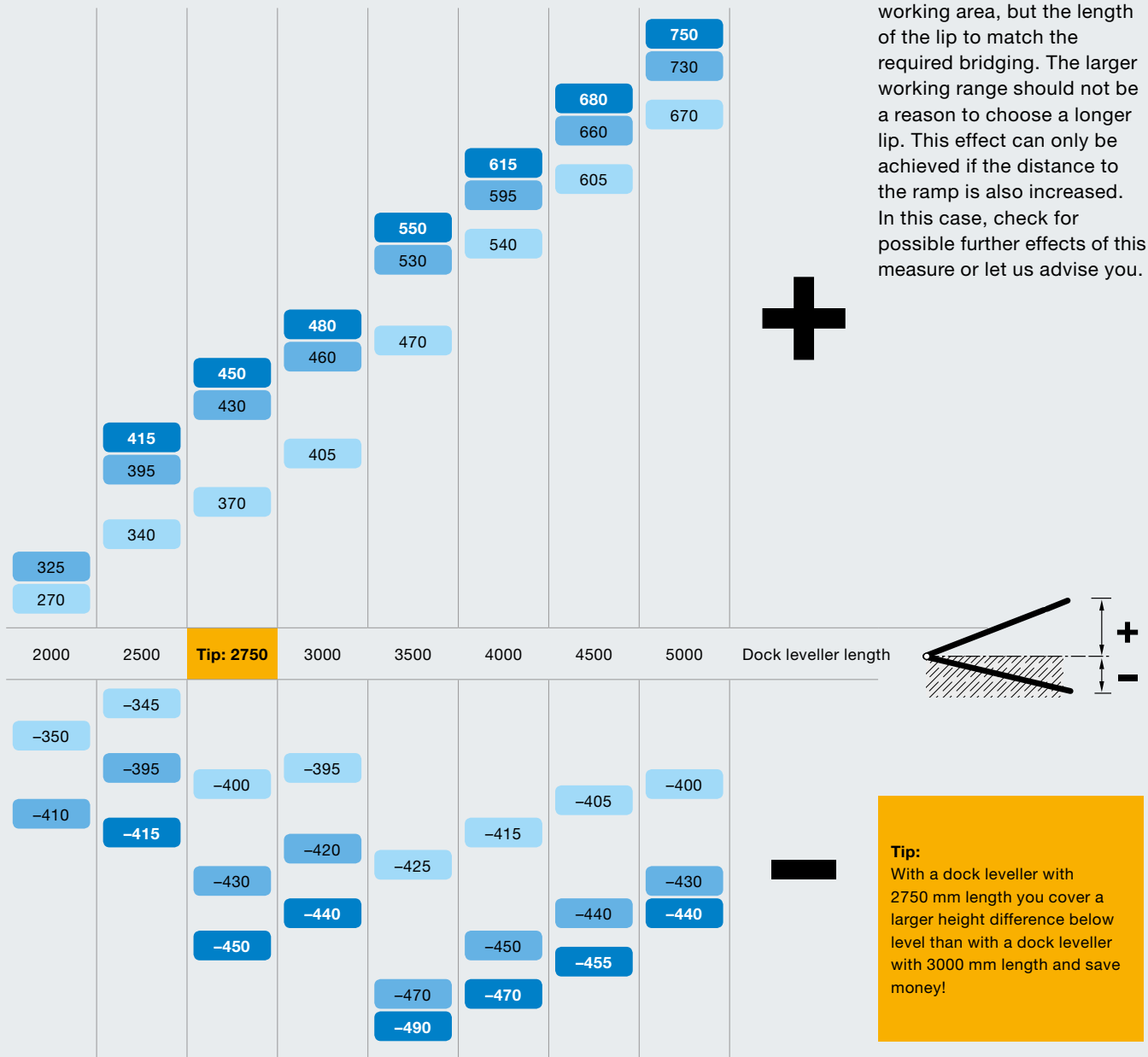

Dimensions

Ordering length										Ordering width
Dock leveller		2000	2500	2750	3000	3500	4000	4500	5000	Dock leveller
Height	HTL 2	595	595	645	645	745	745	745	745	2000, 2100, 2250
Ramp height	HRT	975 - 1425								2000, 2100, 2250 overall width 3500 mm

All dimensions in mm

Hydraulic dock levellers

Controls

User-friendly: simple operation

Hörmann controllers are clear, simple and well designed. An LED light **1** shows the operation status.

Hinged lip dock levellers are operated with one button via press-and-hold **2**. As soon as the platform has reached its highest level, the lip will automatically fold out. Operation of the platform and lip is separate with telescopic lip dock levellers. Furthermore, two separate buttons for extension **3** and retraction **4** allow exact placement of the telescopic lip.

Hörmann advantage: 1-button operation of telescopic lip dock levellers

Operation of telescopic lip dock levellers is extremely convenient if the loading surface is not higher than the ramp: the dock leveller can then be moved into position by simply pressing the "Extend telescopic lip" **3** button. The platform automatically raises a few centimetres before the telescopic lip extends.

Convenience as standard: automatic return to the home position **5**

With only one impulse, the dock leveller is completely returned to the home position. This equipment is standard with Hörmann dock levellers!

Particularly compact: combination control 420 Si / 420 Ti

This solution combines **6** door operation **7** with a standard dock leveller control in a housing.

The advantages:

- Easy to fit
- Inexpensive
- Compact
- Suitable for sectional door operator WA 300 S4 and rolling shutter operator WA 300 R S4 with integrated control

Compatible and combinable: Hörmann industrial controls **8**

The controls for doors and dock levellers are characterised by a uniform operating concept with standardised housing sizes and uniform cable sets. The base and cover of the controls can be removed in just a few steps. Punched holes allow for easier cable routing.

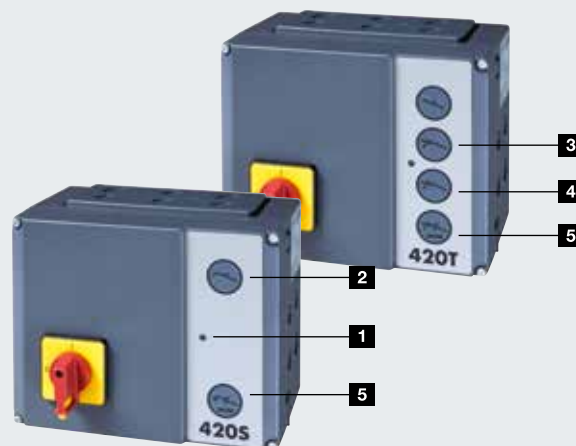



Comfort control with additional functions

With the 460 S or 460 T control, you can also connect warning lights and implement other comfort functions:

Double 7-segment display **9**

- With operation and error display for convenient menu readout and programming
- Service menu with maintenance, cycle, and operating hours counter, as well as fault analysis
- Readout of the last 5 error messages

Integrated operation of the dock shelter **10**

The operation of an inflatable dock seal or electric top flap is already integrated.

Automated processes via semi-operation sequence control

With the appropriate equipment, the door opens automatically as soon as the dock seal is inflated or the electric top flap is lowered. When the dock leveller has returned to the home position after loading, the door closes automatically and the dock shelter switches off or the top flap extends.

External controls

Operation with a view of the area of travel is a basic safety requirement according to EN 1398.

If the dock leveller control is mounted in the building for loading houses, the area of travel is not completely visible. In DOBO systems, the open lorry door blocks the view of the dock leveller from the control housing. External controls, on the other hand, guarantee standard-compliant and safe operation.

DTH-S with fixed wiring **11**

- for hinged lip dock levellers in loading houses

DTH-T fixed wiring **12**

- for telescopic lip dock levellers in loading houses

DTH-T coiled cable **13**

- for telescopic lip dock levellers in DOBO situations

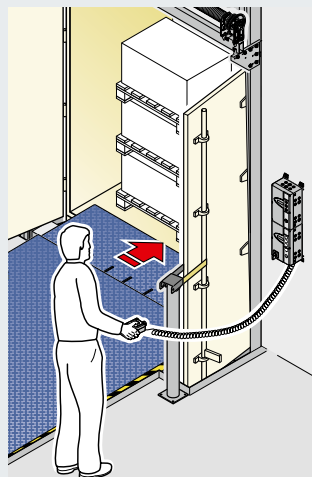
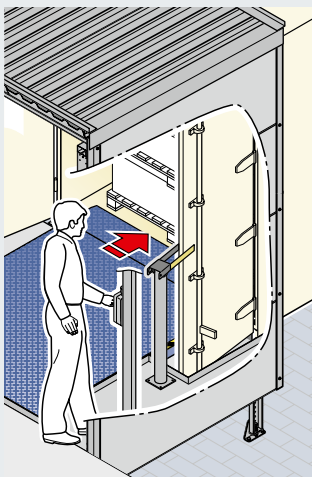

Hydraulic dock levellers

Controls



	Hinged lip dock levellers			Telescopic lip dock levellers		
Control	Basic control 420 S	Combination control 420 Si	Multi-control 460 S	Basic control 420 T	Combination control 420 Ti	Multi-control 460 T
Control in protection category IP 65 (jet-water protected)	●	●	●	●	●	●
LED operation indicator	●	●		●	●	
7-segment display with operational and error display			●			●
Prepared for connection of wheel chock with sensor	●	●	●	●	●	●
Prepared for the dock leveller release function	●	●	●	●	●	●
Prepared for the door release function	○	○	●	○	○	●
Comfort telescopic lip operation				●	●	●
Automatic impulse return	●	●	●	●	●	●
Integrated control button for dock shelter			●			●
Integrated door operation		●			●	
Automatic door closing function			○			○
Semi-operation			○			○
Expanded connection options			●			●
Energy saving mode	●	●	●	●	●	●

● As standard

○ with corresponding equipment



Energy saving mode

When this function is activated, the control enters a virtually de-energised state in home position. Energy consumption in the energy-saving mode without any connected accessories: approx. 2 W/h for 420 S/T, approx. 6 W/h for 460 S/T. This results in electricity savings of approx. 80 %.

Special control construction

Hörmann is your partner for special solutions



Hörmann offers you a complete and individual control concept from a single source: From the integration of the Hörmann special control into your control concept via a complete central control for all functional processes, up to a PC-based visualisation of all door and loading components.

High-quality individual components, compatible with the Hörmann operator technology

Each special control is based on a Hörmann serial control. For additional components, such as programmable storage controls, switching elements, etc. we only use standardised, tested components by high-quality suppliers. This ensures reliable and long-term functioning of the special control.



Individual practical tests ensure easy handling

In addition to process and system tests, in combination with voltage and isolation tests, we generally also test our special controls in practical application. In addition to optimal functioning, this also guarantees high user friendliness.

Individual product development

The entire electrical planning is developed and tested in-house. The electrical documentation is prepared via E-Plan and guarantees great modularity and comprehensibility of the wiring scheme. Integration into customer-specific systems includes technical co-ordination with the customer requirements or the factory standards.



Controlled processes through visualisation

You control, monitor and manage the entire control system via a graphic user interface. It is presented on a control panel or via a web application.

Fitting variants

Hydraulic dock levellers for fitting by welding

Dock levellers HLS as well as HLS 2 and HTL 2 as pit model P

For reliable operation of the dock leveller, the reliable connection to the building structure is of crucial importance. Dock leveller HLS as well as HLS 2-P and HTL 2-P as pit models are placed and welded in an existing concrete opening that is already equipped with edge brackets.

Important:

- Exact and detailed execution of the pit
- Sufficient anchoring of the edge bracket
- Consideration of all forces that can be introduced into the building

Fitting by welding in the front area

Pit edge bracket

Welding on the vertical edge bracket is possible with

- 1 hinged lip dock levellers HLS 2-P
- 2 hinged lip dock levellers HLS for fitting in a pit without tailboard slot

Anchored steel plate

Fitting of the front beam requires an additional steel plate at the front of the pit for

- 3 telescopic lip dock levellers HTL 2-P
- 4 hinged lip dock levellers HLS for fitting in a pit with tailboard slot

Fitting by welding on the rear

Dock levellers HLS 2-P and HTL 2-P can be optionally equipped with an angle profile 5 or an anchor bracket 6 on the rear. For the angle profile, the pit must be made 7 cm longer than the ordering length of the dock leveller. Welding is particularly easy with the version with anchor brackets. The pre-milled rear side indicates the exact position and length of the weld seam. An additional advantage during loading: The transitions remain flat thanks to the recessed weld seam. Dock levellers HLS as well as loading platforms HRS and HRT* are delivered with this equipment as standard.

* Side elements removed

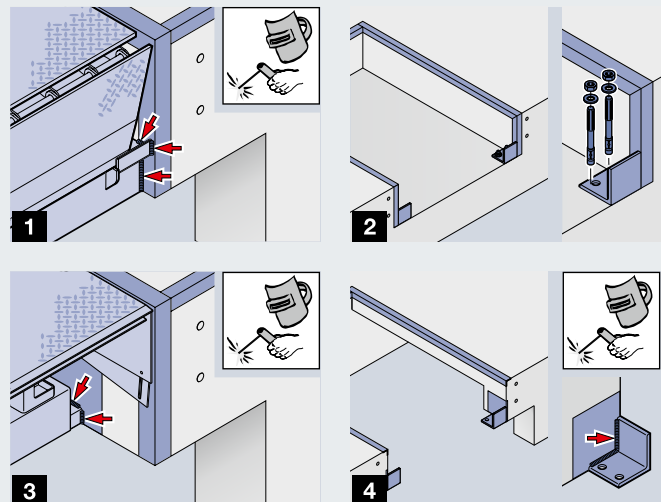



Rear view pit model P with angle profile, delivery including lifting equipment

Simple modernisation

The pit model is best suited for refurbishment. For different pit dimensions or missing connection points, different adjustments are possible depending on the situation at the dock leveller itself or for the pit. Let us advise you!



Remove old dock leveller, adjust pit if necessary (e.g. with fitting plates or support brackets)

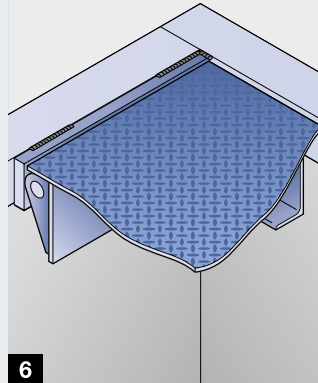
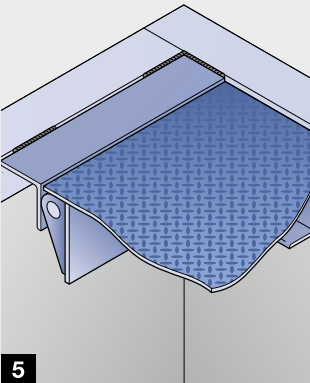

Position the new dock leveller



Weld to the edge brackets – done!

Fitting variants

Hydraulic dock levellers as a frame model

Dock levellers HLS 2 and HTL 2 as frame models FR / B / F

These designs have a self-supporting frame with an all-round edge bracket on three sides and closed sides. Depending on the design, they can be cast during the construction phase or subsequently welded.

Fitting by casting with prefabricated concrete parts **1**

When constructing a building with many loading bays, it is common practice to use prefabricated concrete elements. Dock levellers HLS 2 and HTL 2 as fitting model FR can be simply installed during the construction phase. The anchors are either welded to the reinforcement or rowlocks before the dock leveller is cast. This creates a consistent concrete ceiling.

Flexible casting height

Frame model FR is available for different casting heights from 100 mm to 250 mm. The rear of the dock leveller is adjusted at the factory so that the concrete cannot run under the dock leveller.

Fitting by casting in a pit **2**

The dock levellers HLS 2 and HTL 2 as FR models are also suitable for fitting in a pit provided with a casting groove.

Fitting by casting with a formwork construction **3**

With this fitting method, dock levellers HLS 2 and HTL 2 are supplied as box model B with a casting box. The design is completely closed on the rear and equipped with reinforcement profiles on the sides, so that the side panels do not deform when casting along entire height.

Subsequent fitting by welding **4**

Dock levellers HLS 2 and HRT 2 as frame model F are intended for subsequent, simple fitting by welding. This can be a good alternative

- if it is not yet clear which lip version is required, for example
- as the aim is to prevent the dock leveller from being damaged during the construction phase.

A preassembled frame is cast into the pit during the construction phase. Unlike pit model B, frame model F is simply hung into the pit and then welded on three sides.

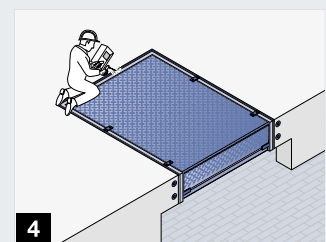
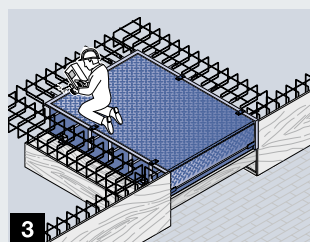
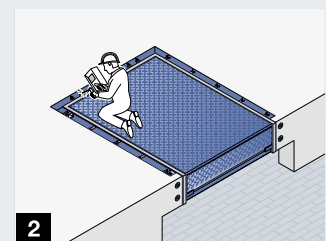
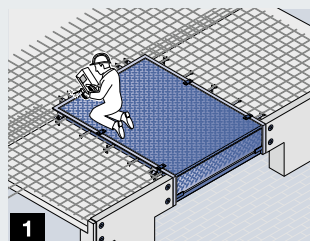



Rear view of frame model FR
(Fig. shows casting height of 200 mm)



Rear view of box model B



Rear view of frame model F



Preassembled frame

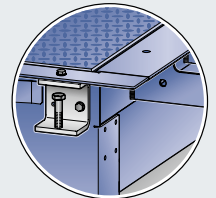
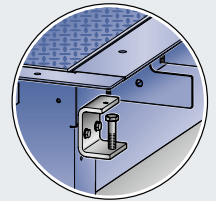

Adjustable angle and fitting anchors

With the screw-on adjustment brackets you can align the dock leveller optimally. They are pre-assembled at the factory according to the desired casting height, but can be easily repositioned if necessary. The particularly stable anchor brackets on the frame are welded to rowlocks or reinforcement before casting and ensure a reliable connection. Especially on the rear, where strong forces act on the hinges.



Practical ventilation holes

Air pockets, which may above all form in the area below the edge bracket, weaken the connection of the dock leveller to the building structure. Above all, the area below the edge bracket is at risk here. Ventilation holes in the edge bracket allow air to escape during compression and thus ensure a positive connection.

Hydraulic dock levellers for special requirements

Special solutions for lorries and transit vans on a loading platform

Important: clarify the height differences to be bridged!

Loading and unloading lorries and vans on the same ramp – something that is becoming increasingly requested. The resulting height differences decide whether this makes sense and is possible.

Lorries and swap trailers on one side and transit vans on the other side usually require different ramp heights. The loading surface heights for vans are much lower than those for lorries and swap trailers. As a result, slopes can arise, which are no longer practicable for loading and unloading depending on the means of transport. We therefore generally recommend separate loading points.

Dock leveller HTLV 3 with 3-part telescopic lip

If the ramp height and dock leveller length are selected so that an inclination angle suitable for the loading process is created on all docking vehicles, dock leveller HTLV 3 with 3-part telescopic lip can be a space-saving alternative to separate loading bays. A more favourable inclination angle can be achieved with a longer dock leveller.

For lorries, the entire telescopic width (about 2000 mm) can be pushed out steplessly. With a rated load of max. 60 kN, the HTLV 3 can be used like a conventional dock leveller.

A simple switch on the control lets you extend the centre section of the telescopic lip, while the side parts remain mostly behind, making it ideal for delivery vans. An intelligent and patented hydraulic system provides the necessary weight compensation to reduce the strain on the delivery van. The dock leveller follows the movement if the loading surface of the delivery van is lowered during loading. This ensures proper positioning at every point. The dock leveller can be loaded in this mode up to 20 kN acc. to EN 1398.

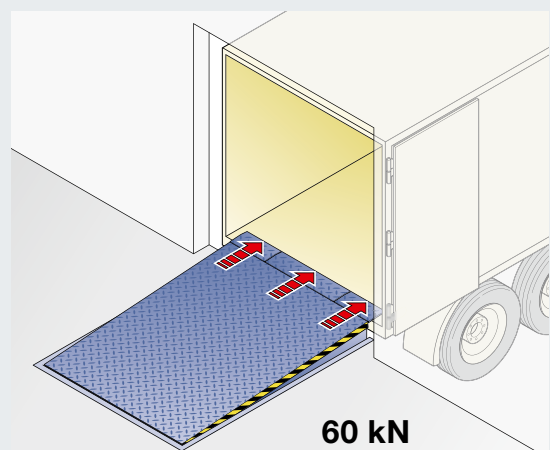



Working range and dimensions

The maximum difference in height that can be bridged, taking into account the maximum gradient / inclination according to EN 1398 of 12.5 %:

Length of dock leveller (ordering length)	3000	4500
	420	490
	490	540
	570	630
	650	690
Height	795	895
Ordering width	2000	2000

Lip length:

500 mm

1000 mm (optional)

All dimensions in mm

Tip:

With a longer lip, you cannot reach a larger work area, unless you increase the distance between the vehicle and the ramp!

In order to protect the dock leveller from damage during the construction phase, we recommend the frame model F.

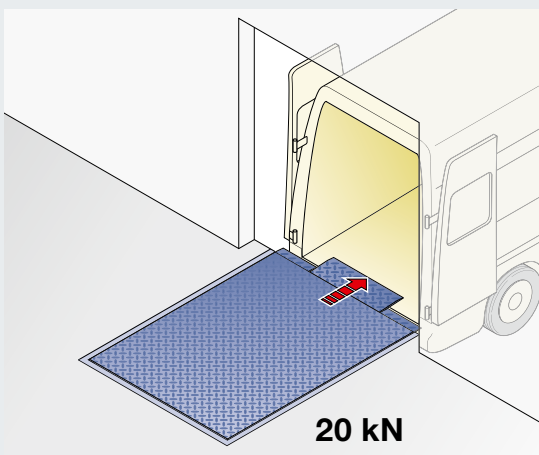

Hydraulic dock levellers for special requirements

Combination of telescopic lip dock leveller and scissors table lift

Lift levellers

The lift leveller is used to perform two very different functions in the most limited space:

Lift leveller as a dock leveller **1**

At the ramp level, the lift leveller functions like a conventional hydraulic loading dock leveller: it bridges the distance and any difference in height to the lorry loading surface, thus enabling an efficient loading process.

Lift leveller as a scissors lift table **2 3 4**

Thanks to the integrated scissors lift table, it is also possible to lift goods from the roadway level to the building floor easily and quickly, or vice versa, to lower them from the building to the roadway level. The function as a dock leveller is blocked in this situation.

Tip:

Transporting persons on the scissors lift table is not permitted! Plan the passage of pedestrians at close proximity.

Working range and dimensions

The maximum difference in height that can be bridged by the dock leveller function, taking into account the maximum gradient / inclination according to EN 1398 of 12.5 %:

Ordering length	2750	3000
	340	370
	395	430
	345	400
	395	430
Ordering width	2000 – 2100 – 2250	

Lip length:

500 mm

1000 mm (optional)

Maximum different in height that can be bridged in its function as a scissors lift table: 1250 mm

All dimensions in mm

Important: the pit must be designed in such a way that no pinching and shearing points occur! The area under the lift table must not be accessible. A door in front of the lift leveller down to roadway level or a front protection plate can guarantee this.



Hydraulic dock levellers with integrated RFID technology

Non-contact reliable recording of the transport goods when crossing the dock leveller



Automatic recording of goods movements, simply while crossing the dock leveller.



Reliable data transmission along the shortest path between the RFID transponder and the reader.



9/9 Objekte **99,8kg**

The delivery note with the information on the goods and the linked transponder number is displayed. The completely loaded goods are then marked (Fig.).

Only from Hörmann

The share of euro-pallets equipped with RFID technology is steadily increasing, in line with the increasing demand for the automated flow of goods.

Frequently, the required RFID readers and antennas in the form of a gate are elaborately installed around the loading ramp door. Disadvantages of this installation: it occupies valuable space, collisions with the lorry can lead to equipment damage and undesirable shielding effects and excessive ranges can occur.

The shortest path is the best

When the transponder is fitted onto the pallet, the antennae should also be installed nearby. The solution: the antennas are fitted directly underneath the dock leveller, which is permeable to RFID radio signals. With this patented solution, the transponder data reliably reaches the reader via the shortest route, directly when crossing the dock leveller.

Advantages at a glance:

- Reliable transmission due to short distance between the reader and transponder
- The RFID reader is securely fitted underneath the dock leveller, preventing collision or mechanical impact damage
- Minimal soiling due to the protected location of the readers
- Cable-based, stable and reliable data transfer from the reader to the follow-up IT station
- Very economical because only the dock leveller must be equipped with the RFID technology, and not industrial vehicles such as forklifts

Seek individual consultation. On request, real loading tests can be performed with your returnable containers and special loading units on a test ramp. Consulting and project planning takes place in cooperation with experienced IT logistics specialists.



Take a look at the video "Dock levellers with integrated RFID technology" at: www.hoermann.com/mediacenter

DOBO system

Docking before opening

DOBO principle

On conventional ramps, the driver gets out of the vehicle, opens the vehicle door and then docks the vehicle. If the vehicle has already docked on the previous evening, inconvenient adjustment processes are necessary to open the doors. With the DOBO system, a lorry can dock with its doors closed. They can be opened whenever needed. Until that time the goods remain well protected inside the vehicle.

Advantages:

- **Speed docking:** no manoeuvring and getting out to open the doors, approx. 5 min. time saving per lorry
- **Use of swap bodies:** dock in the evening, unload in the morning
- **Increased occupational safety** through safe docking without disembarking: minimised risk of accidents in the danger zone between the vehicle and the ramp
- **Theft protection:** The door can remain closed until the actual loading process, the lorry doors are blocked against opening until the buffers are lowered; relevant for customs purposes: the lorry can already be piloted to the loading point, the seal can be released from the inside
- **Closed cooling chains**
- **Hygienic loading:** entry of animals and debris is avoided
- **Energy cost savings:** unnecessary temperature exchange is reduced; due to the door guide in front of or behind the dock leveller, the dock leveller is not a thermal bridge

Tip:

Realisation of the DOBO system in the loading house is particularly simple. Compared to fitting in the building, the on-site production of a pit with recesses for vehicle doors and building door as well as the insulated panel below the dock leveller is eliminated.

DOBO system in the building

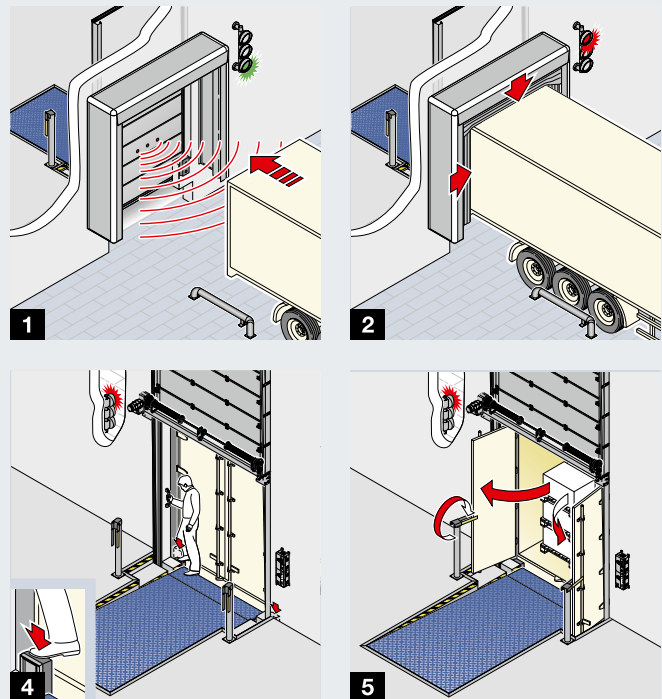

DOBO system in the loading house

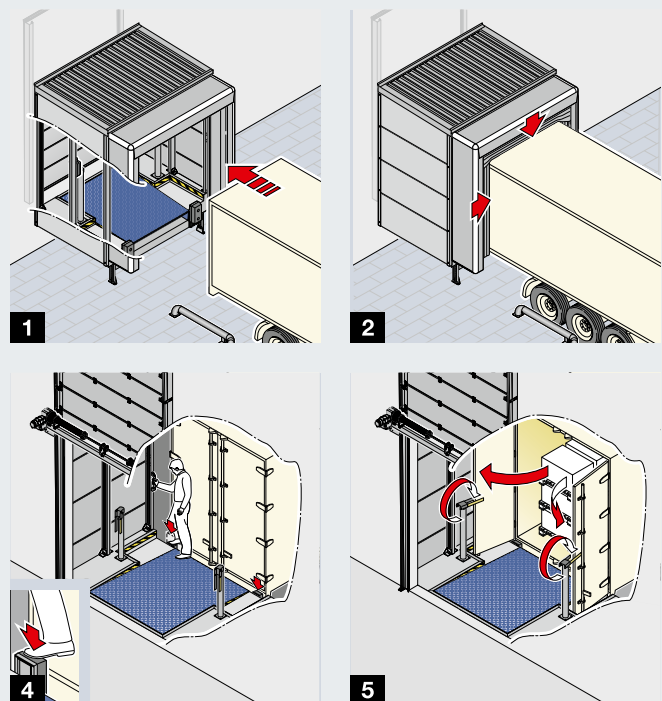

Take a look at the video "DOBO system" at:
www.hoermann.com/mediacenter

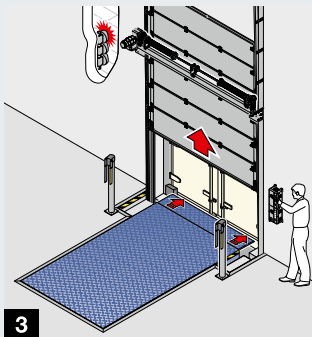

3

1 Safe docking

The drive-in aids and the Hörmann Docking Assistant HDA-Pro support the driver in safe and centred docking. The vehicle doors remain closed. Sensors in the door leaf recognise the position of the vehicle. Alternatively, the DAP docking assistant can be used.

2 Reliable sealing

As soon as the lorry is docked, the dock shelter DAS 3 is inflated and seals the vehicle on three sides.

3 Opening the dock door

After the door is completely opened, the telescopic lip of the dock leveller is extended to decrease the gap to the vehicle.

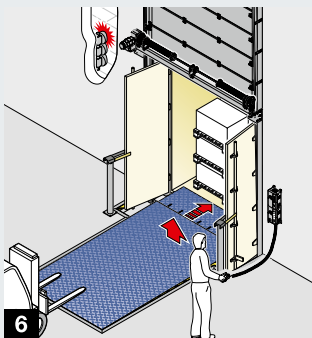

6

4 Lowering the buffers

Now the movable buffers VBV4 or VBV5 can be lowered and locked to open the lorry doors.

5 Opening the vehicle door

The ramp features a recess that provides enough space for the door to open completely.

6 Extending the dock leveller

The dock leveller HTL2 with a 1000-mm-long telescopic lip easily bridges the gap between the ramp and loading surface and can be precisely positioned up to the last centimetre.

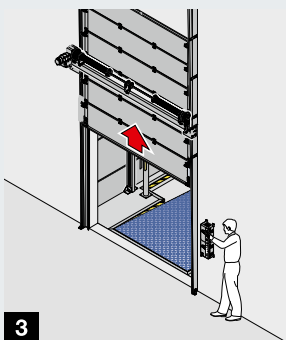

3

1 Safe docking

The drive-in aids and the DAP docking assistant support the driver in centred docking.

2 Reliable sealing

As soon as the lorry is docked, the dock shelter DAS 3 is inflated and seals the vehicle on three sides.

3 Opening the dock door

The door can be fully opened to gain access to the front area of the loading house.

4 Lowering the buffers

Now the movable buffers VBV4 or VBV5 can be lowered and locked to open the lorry doors.

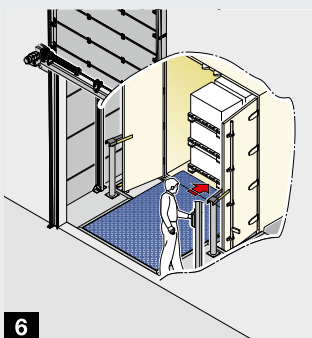

6

5 Opening the vehicle door

The ramp features a recess that provides enough space for the door to open completely.

6 Extending the dock leveller

The telescopic lip dock leveller with a 500-mm-long telescopic lip easily bridges the gap between the ramp and loading surface and can be precisely positioned up to the last centimetre.

DOBO system

Components

DOBO system in the building* 1

- **On-site recess in the building floor** for the vehicle doors
- **On-site recess in the building** to guide the building door in front of the dock leveller
- **Dock leveller HTL 2 DOBO-h** with 1000 mm long extension, horizontal home position (cross-traffic possible to a limited extent)
- **External operation DTH-T** for optimum visual contact with the dock leveller despite open doors
- **Insulated panel** or concrete floor under the dock leveller
- **Dock shelter DAS 3 DOBO** (see page 58)
- **Sectional door SPU F 42** or SPU 67 Thermo
- **Door holders 3** prevent the vehicle doors from swinging back during loading
- **Buffers VBV4** or **VBV5 4** (see page 69)
- **Docking system HDA-Pro** or **DAP** (see right side) to prevent damage to the building structure, especially in the area of the on-site recess
- **Query of the door open end-of-travel position**, e.g. magnetic switch, for the function dock leveller release



DOBO system in the loading house* 2

- **Loading platform HRT DOBO-s** with recess for the vehicle doors, low home position (door opening possible at any time)
- **External operation DTH-T** for optimum visual contact with the loading house
- **Loading house design** (see pages 44 – 45)
- **Dock shelter DAS 3 DOBO** or **DAS 3-L DOBO** (see pages 58 – 59)
- **Industrial sectional door SPU F 42** or SPU 67 Thermo as a building door
- **Door holders 3** prevent the vehicle doors from swinging back during loading
- **Buffers VBV4** or **VBV5 4** (see page 69)
- **Docking system DAP** (see page 76)
- **Query of the door open end-of-travel position**, e.g. magnetic switch, for the function dock leveller release

* This list of components is exemplary and may vary as needed.

When planning, pay special attention to the movement range of the doors.





3



4

Docking systems

While manoeuvring, the colour of the warning light tells lorry drivers how far they are from the dock.

Docking assistant DAP with optosensors
For further information, see page 76.

Docking Assistant HDA-Pro with several sensors on the door leaf, which recognise the rear of the lorry with closed rear doors (the system is only suitable for DOBO systems in the building, see page 38 / 40).

Docking phases:

- 5 Green warning light: vehicle can dock
- 6 Yellow warning light: vehicle is approaching the docking position
- 7 Red warning light: docking position reached

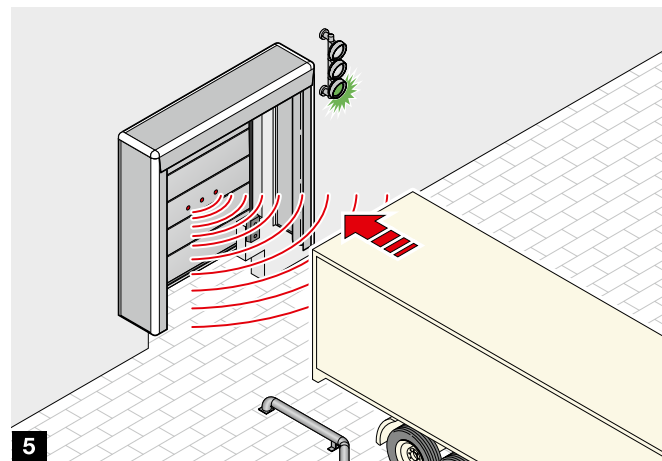

5

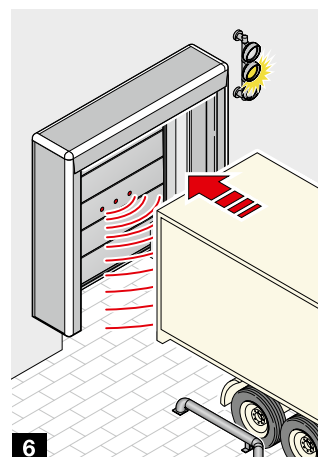

6

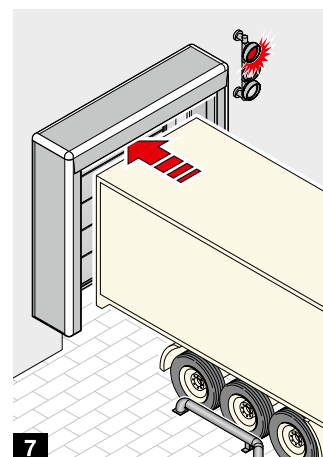

7

Loading houses

Product and planning advantages

Practical construction

Loading houses are especially recommended for commercial buildings and for renovation purposes, as a complete loading bay can be added to the building without costly reconstruction measures. In addition, the building can be fully utilised right up to the exterior walls, or the building can be planned smaller for new buildings.



Energy-efficient concepts

Loading houses offer enormous potential for energy savings as the building ends with a thermally insulated industrial door and the dock leveller is placed in front of it. This way, the door opening is optimally insulated, especially outside loading times. The version with DOBO system is particularly energy-efficient.



Space-saving solution

Loading houses can be arranged at different angles, depending on the available exterior area, so as to create sufficient room for movement for docking. With a large number of required loading bays, coupled loading houses can create both inexpensive and visually appealing facilities.



Application areas

The right loading house for any requirement

Protection of personnel and goods against adverse effects of the weather

- **Type LHC 2**
with single-skinned cladding

For further information,
please see page 46.



For protection against the influences of weather and to reduce noise during loading

- **Type LHP 2**
with double-skinned cladding

For further information,
please see page 46.



For perfect adjustment to the facade design

- **Type LHF 2**
for on-site cladding

For further information,
please see page 46.



Loading houses

Certified sturdy construction with lean design

Overall construction resistant to working stresses

Hörmann loading houses meet all requirements regarding stability and safety with their narrow design. The proven construction carries a roof load of max. 1 kN/m² or 3 kN/m² and is also recommended for snowier regions. The max. wind load is 0.65 kN/m². Thus, with Hörmann you can plan loading houses simply and safely. For higher requirements, please speak to your Hörmann partner.

The frame construction and the steel pedestals of the loading house are certified according to EN 1090, an important condition for meeting the requirements of the Construction Products Regulation. The certificate confirms fulfillment of the requirements such as

- In-factory production control
- Durability
- Measurement according to the Eurocode.

A static calculation according to EN 1990 is available for all models. Together with the CE label and the online declaration of performance, the conformity of the pedestals and loading houses with the Construction Products Regulation is consistently demonstrated.

Space requirements

For loading houses there is increased space requirement in the outside area **1**.

Arranged at angle

In limited space, the angular arrangement achieves more room to move for docking **2**.

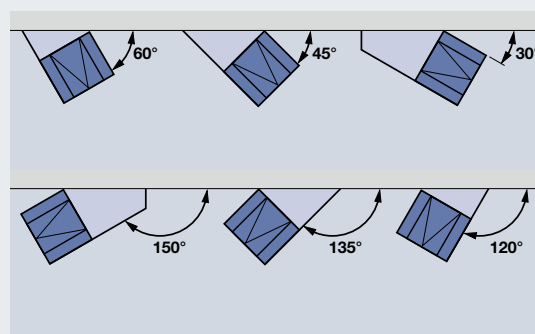
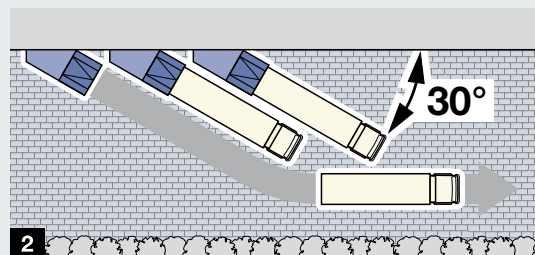
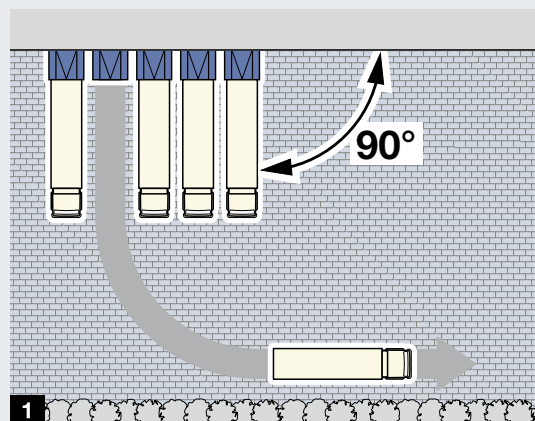

 Take a look at the video "Loading houses" at: www.hoermann.com/mediacenter



3 Base frame as a dock leveller pedestal combination

The loading platforms HRS and HRT form the optimal subframe for the loading house with dock leveller and side elements as a matched unit. The front plates are already prepared for fitting the buffers. For high-quality corrosion protection in outdoor areas, the HRS or HRT in galvanized design is recommended. Loading platforms HRS and HRT are available up to 3 m in length and with a rated load of 60 kN. For higher requirements, dock levellers type HLS 2 or HTL 2 are combined with separate pedestals.

4 Adjustable pedestal feet

The height of the loading house pedestal feet can be adjusted to optimally adapt to the building level. This facilitates fitting and also allows any building subsidence to be compensated, even after many years.

5 Optimum drainage

Loading houses are drained to the front with a standard roof inclination of 2 %. A roof inclination of 10 % is possible as a option under certain circumstances. On request, a rain gutter can also be fitted in conjunction with a drainpipe **6** on the loading house.

7 Complete with dock shelter

A dock shelter complements the subframe and the building structure to produce a complete loading bay. It can easily be fitted to the frame construction of the loading house. The solution with an inflatable dock seal is particularly energy-efficient, which is integrated well protected in a loading house recess, see page 59.

Close connection to the building structure

A 50-mm-high bottom roof bracket connects the construction with the building structure and ensures a close connection. An optional cap strip prevents the entry of rainwater. For building facades that cannot accommodate vertical loads, the loading house is available as a self-supporting version. Only wind loads are transferred to the facade.

Loading houses

The right version for any requirement

Single-skinned: type LHC 2 ¹

The single-skinned cladding effectively protects staff and goods against the influences of weather during loading. The max. roof load is 1 kN/m² as standard, optionally 3 kN/m². The inside of the roof can be supplied to be condensate inhibiting on request. For roof loads up to 3 kN/m², the roof is made with sandwich panels and additional condensate-inhibiting equipment is not required.

Double-skinned: type LHP 2 with 60-mm-thick steel panels ²

The side walls and the roof panel are made of double-skinned 60-mm-thick steel panels. Type LHP 2 is particularly recommended in addition to the protection against weather influences to inhibit the noise transmission during loading and to prevent the effects of heat on refrigerated goods due to sunlight.

This loading house carries a roof load of up to 3 kN/m² as standard. For an appealing view, the side walls are concealed without visible screws.

Surfaces LHP 2 side walls and roof panels:

- ³ LL
- ⁴ M8L
- ⁵ M16L

Reliable surface protection

The loading houses type LHP 2 and LHC 2 are delivered primed, inside in RAL 9002, the side and roof cladding on the outside either in RAL 9002 or 9006. Coloured wall panels are available on request.

Unlimited design variety: type LHF 2 ⁶

Any suitable cladding can be fitted on the frame construction on-site - recommended if the facade of the building should also determine the view of the loading house (see page 43, above). Also possible: preparation of the loading house for vertical cladding.

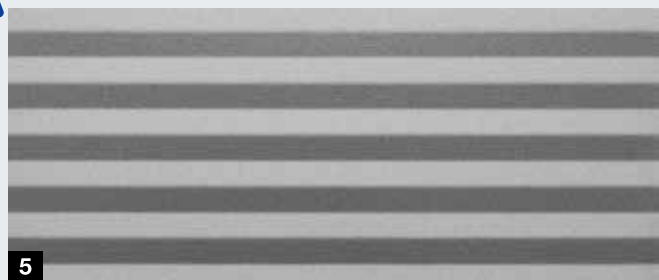
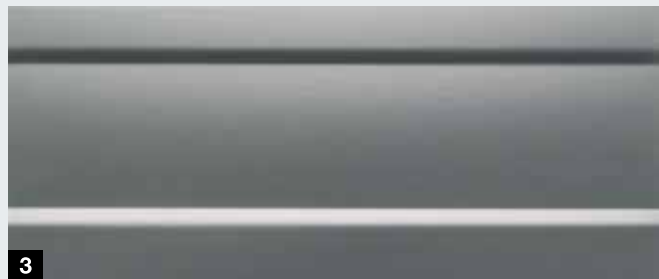
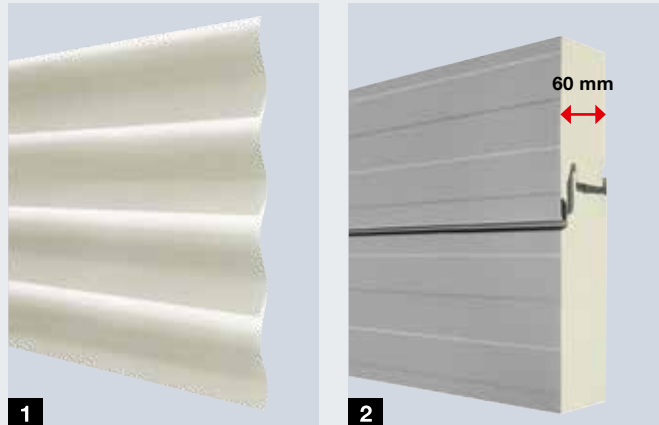



Optimum thermal insulation: thermal loading house 7

If the loading house is located directly inside a cooling zone, there are considerably higher requirements for thermal insulation. Hörmann insulated loading houses are equipped with a 80-mm-thick sandwich cladding in the roof, wall and floor areas. For the front closure we recommend an industrial sectional door SPU 67 Thermo with 67 mm depth.

Important: thermal loading houses must be effectively dehumidified. All joints must be professionally and appropriately sealed by a specialist company for cooling and refrigeration technology.

Loading houses with DOBO system 8

A DOBO system can be implemented particularly easily with loading houses as it can be placed in front of the building. The subframe of the DOBO dock leveller with stepped side elements is already prepared for the fitting of a standard loading house.

For further information on the DOBO system see page 38 – 41.

Coupled facilities 9

With large facilities, coupled loading houses arranged in a row can provide both an inexpensive and visually appealing alternative. Prerequisite:

- Arrangement 90°
- Axle size max. 4000 mm (distance middle – middle of dock leveller)

The roof clad with sandwich panels takes loads up to 1.75 kN/m², optionally up to 3 kN/m².

Front door closure 10

In order to protect the loading house from unwanted influences and soiling even outside of loading times, **rolling shutter Decotherm SB** can be fitted in the front area. Fitting of a sectional door is also possible, but requires a higher loading house due to the space required for the door guide and possibly also a longer dock leveller.

Dock shelters and seals

Product and planning advantages

Effective protection

Dock shelters seal the space between the building and the lorry. They protect goods and people against the influences of weather when the door is open. They also effectively reduce loss of heat due to ventilation during the loading and unloading process and therefore save energy costs.



Optimal solution

Dock seals and shelters are particularly efficient when they are optimally adapted to the docking vehicles and the loading situation. Hörmann offers a wide range of flexible version with individual equipment.



Long-lasting design

In order to effectively prevent damages during docking, the frame constructions of the flap dock shelter is particularly robust and flexible at the same time. The cushions of inflatable dock seals are well protected in the home position and are not in contact with the vehicle when docking. Only then do they effectively enclose the vehicle.



Application areas

The right dock shelter for any requirement

Universally applicable for different vehicle sizes

- Flap dock shelters

For further information, see pages 50 – 55.



For completely clear loading openings and energy-saving loading concepts

- Inflatable dock seals

For further information, see pages 56 – 59.



For vehicles with comparable dimensions and the same structure

- Cushion dock seals

For further information, see pages 60 – 63.



Flap dock shelters

Flexible frame construction

1 Sturdy steel frame

The top and side flaps are fitted on a galvanized, pressed-steel frame and form a stable and robust overall construction.

2 Flexible link arm construction

The link arm construction is flexible both horizontally and vertically due to its design and the special open profiles. When pushing in the dock shelter, the front frame moves slightly upwards.

3 Telescopic link arms

This optional extras allows the front frame to follow lorry lifting movements. The risk of damage from swap levellers that need to be raised for stopping or vehicles that pump up after docking is easily minimised with this patented design. The front frame can move upwards up to 250 mm. Telescopic link arms can also be retrofitted.

Important:

If there are any canopies, ensure sufficient space for movement above the dock shelter.

4 Robust scissors arm construction

The advantage of the scissors arm design lies in its rigidity. It also allows very high or deep versions. The frame construction is pressed in parallel and tightens the cladding again by tension springs after the loading process.

5 Planning with spring tension

The side and top flaps are made of double-layered, 3-mm-thick polyester monofilament thread substrate fabric with double-sided UPVC coating. In contrast to conventional polyester flaps, the monofilament threads in the flap material of the side flaps provide clear pre-tensioning to the rear of the lorry and thus an excellent seal.

The side flaps are provided with marking stripes: for link arm versions 1 unit per side, for scissors arm versions 4 units per side, for roadway models 6 units per side.

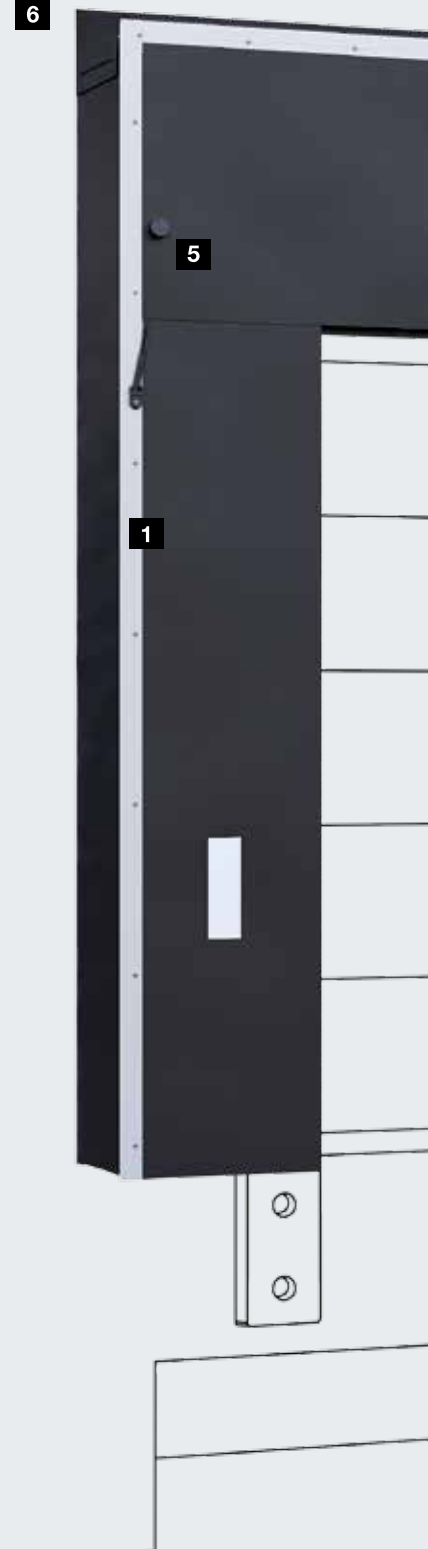
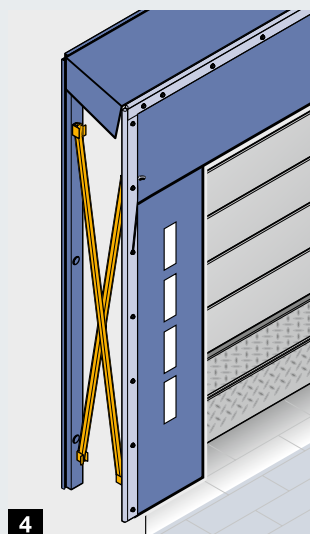
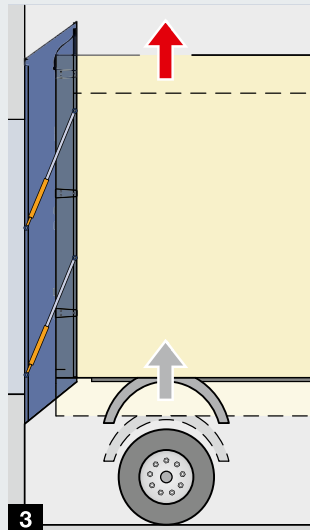
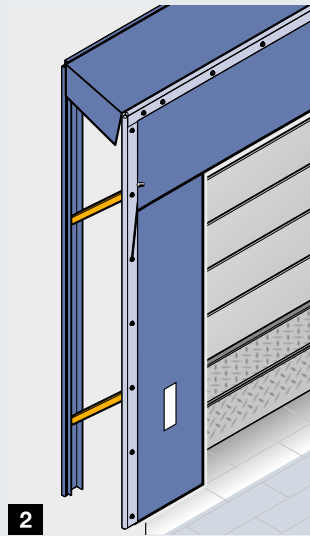



Drainage

Depending on the version, constructive details in the top part ensure effective drainage of rainwater so that people and goods are protected from large amounts of rainwater.

6 Top part with inclination

The front and rear frame on this construction differ in height. The produced inclination of 100 mm channels rainwater off the front edge. The dock shelter can also be equipped with further optional drainage measures, see page 54.

7 Straight top part with gutter

The top cladding of straight top parts is equipped with drainage openings. A water run-off channel drains the rain water towards the side.



Flap dock shelters

Tailored equipment

Top flap versions

For different vehicle heights, flexible top flaps are required. While a long top flap ensures good sealing even with smaller lorries, it hangs over the loading opening of larger vehicles. An overlap of approx. 150 mm is ideal **1**. To prevent the tension on the top flap from becoming too high for higher vehicles, it can be designed with an incision or with a corner or even full sections as required.

2 Top flap with side incision

3 Corner section top flap

4 Fully laminated top flap, 100 % overlapping

In places where small vehicles, such as delivery vans, occasionally dock, an additional roll-up flap makes sense. It is available for manual operation or operation via operator, and can be lowered onto the vehicle roof after docking, if required **5**.

6 Numbers on the top flap

On request, we can supply the top flaps with a number in the colour of the marking stripes.

7 Water drainage channel

For dock shelters that are not located under a canopy, higher drainage requirements may apply. The upper cladding can be equipped with a water drainage channel. For high facades and long service life, the dock shelters with straight top part DSLR, DSSR (-G) are equipped with a water drainage channel as standard.

8 Inflatable corner cushions

Where energy-related aspects play a role, the optional inflatable corner cushions are practically a must. Due to their height and shape, they significantly improve the sealing at the bottom of the dock shelter between wall connection and flap.

9 Bottom flap for roadway version

An optimal seal at the bottom edge of the lorry provides the removable bottom flap, which is hung on the rear frame of the seal.

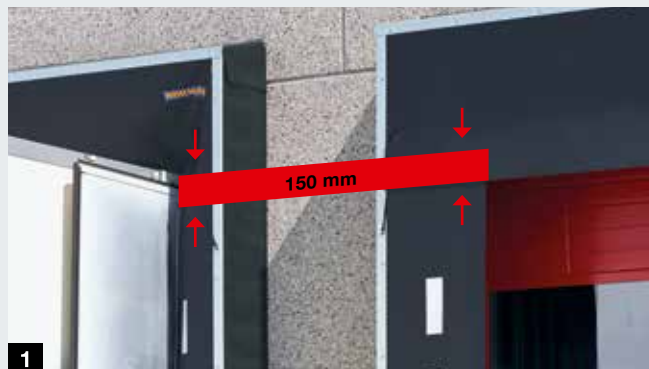

1



2



3



4



5



6



7

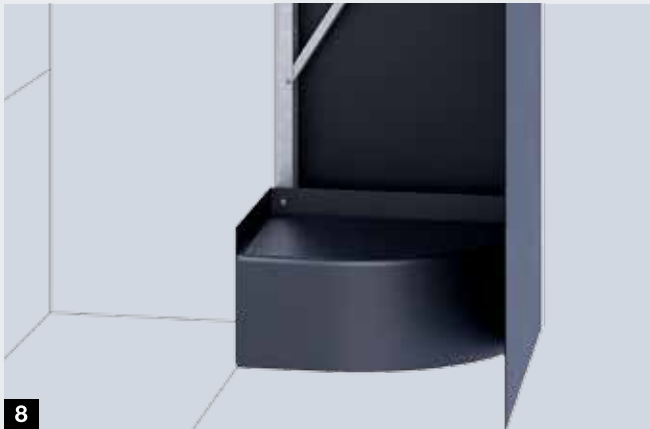

8



9



Graphite black, similar to RAL 9011



Basalt grey, similar to RAL 7012



Gentian blue, similar to RAL 5010



White

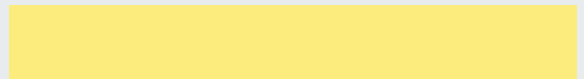

Yellow



Orange



Red

Colours







Top and side flaps	
Graphite black, similar to RAL 9011	●
Basalt grey, similar to RAL 7012	○
Gentian blue, similar to RAL 5010	○
Side cladding	
Graphite black, similar to RAL 9011	●
Basalt grey, similar to RAL 7012	○
Gentian blue, similar to RAL 5010	○
Marking stripes	
White	●
Yellow	○
Orange	○
Red	○

● = Standard

○ = Optional, not for DDF

Flap dock shelters

A wide range of options

Versions	DSL	DSL R	DSS	DSS R	DSN	DSS-G	DSS R-G	DSN-G	
Dock model (Fig. on page 50/51)	●	●	●	●	●				
Roadway model (Fig. on page 53, section 9)						●	●	●	
Link arm	●	●							
Scissors arm			●	●		●	●		
Recess fitting					●			●	
Top part with inclination	●		●			●			
Straight top part		●		●			●		
Marking stripes, number per side	1	1	4	4	1	6	6	4	
Fitting under canopy	●		●			●			
 Ordering width	 Side flap width		 Front opening width						
2800	600		1600						
	700		1400						
3000	600		1800						
	700		1600						
3350	600		2150						
	700		1950						
3500	600		2300						
	700		2100						
 Ordering height	 Top flap height*		 Front opening height						
2800	900		1800 1900						
	1000		1700 1800						
	1200		1500 1600						
3000	900		2000 2100						
	1000		1900 2000						
	1200		1700 1800						
3500	900		2500 2600 2500 2600 2500						
	1000		2400 2500 2400 2500 2400						
	1200		2200 2300 2200 2300 2200						
3750	900		2750 2850 2750 2850 2750						
	1000		2650 2750 2650 2750 2650						
	1200		2450 2550 2450 2550 2450						
4500	900		3500 3600						
	1000		3400 3500						
	1200		3200 3300						
 Depths									
500	●	●	●	●		●	●		
600	○	○	○	○		○	○		
900	○		○			○			

* Top flaps are optionally available in a lower height, from 500 mm high.

● = Standard

○ = Optional

Flap dock shelters DDF

No linkage and with lifting roof







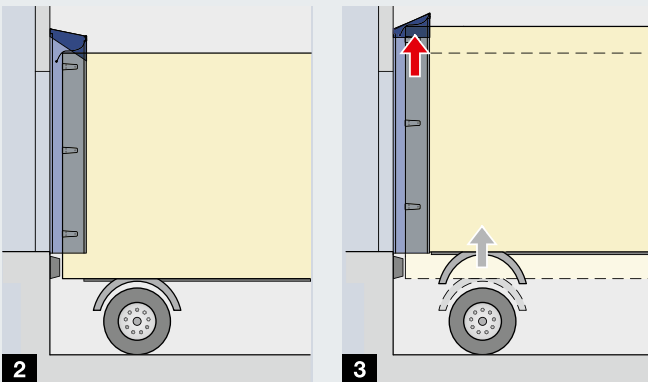

Side cushions and lifting roof

With particularly tear-resistant flaps on foam-filled side cushions, the DDF dock shelter is an alternative to the flap dock shelter with link or scissors arms. The side cushions are simply pressed in the case of inexact docking or move off to the side without any damage. The side flaps are fastened with Velcro fastenings to the side cushions **1**. This allows for simple and inexpensive exchange in case of damage. The top part is upwardly mobile **2** **3**, i.e. it can move upwards approx. 550 mm when a docked vehicle is raised up. The roof shape drains the DDF to the side.

Tip:

Dock models with a size of 3500 x 3500 mm have proven themselves in practice due to their flexibility, as the pressure of the docked lorry can be optimally distributed in the dock shelter. Therefore plan the necessary space requirement in the building plans! For facilities, consider a sufficiently large distance of at least 100 mm between the dock shelters.



Versions		DDF	
Dock model		●	
Side cushion		●	
Lifting roof		●	
White marking stripes, number per side		1	
Fitting under canopy		●	
 Ordering widths	 Side flap width	 Front opening width	Suitable for loading houses
3300	600	2100	-
3400	600	2200	-
3500	600	2300	●
 Ordering height	 Top flap height	 Front opening height	
3500	1000	2450	

Inflatable dock seals

For the highest visual and technical requirements

1 Frame construction

The roof and side cladding made of thermally insulated, 20-mm-thick steel panels are available either in White aluminium RAL 9006 or Grey white RAL 9002, with anodised aluminium corner profiles with a rounded softline look.

2 Flap and fabric

The flap strips made of double-layered, 3-mm-thick polyester monofilament thread substrate fabric with double-sided UPVC coating protect the cushions in home position. The cushions are made of weather-resistant, high-frequency-sealed flap material in Graphite black, RAL 9011.

3 Inflatable top and side cushions

In home position, the inflatable cushions are almost invisible. When docking, there is no contact with the lorry. As a result, somewhat inaccurate docking does not directly lead to damage to the dock shelter.

Important:

The proper cushion dimension ensures optimum sealing. The length of the top cushion and the width of the side cushion must be sufficient to exert some pressure on the docked lorry (special sizes are possible). On the other hand, the top cushion / side cushion must not be so long / wide as to deform when being pushed in.

Optimum front opening in the working position

- Width 200 mm less than the vehicle width
- Height 100 mm less than the vehicle height

Side cushions that are too wide are a particular problem with the DOBO system. They might shift backwards and push against the open lorry doors. This could impair loading and even result in a hazard.

4 Roll-up flap

As an alternative to the top cushions, an electric roll-up flap offers more flexibility at different vehicle heights. **Type RCH** is 2 m long and is lowered in press-and-hold operation. The 3 m long **RCP version** is operated together with the side cushions in impulse operation and follows even the possible dropping of the vehicle. This ensures a constant, good seal.





Blower

The high-power blower is in operation during the entire loading process and thereby guarantees a consistent seal. A 1-phase 230 V supply line is required for connection. After switching off, the cushions quickly retract through internal tensioning cables and counterweights.

Operation

The inflatable dock seal can be conveniently operated with the comfort dock leveller control 460. Integration in automated processes is also easy. Alternatively, operation via a switch is possible.

Numbers 5

On request, the top flap can be equipped with numbers to mark the loading ramp.

Marking stripes 6

On request, the side flaps have three white marking stripes on each side.

Inflatable corner cushions

The DAS 3 is fitted with foam-filled inflatable corner cushions as standard for sealing in the bottom section, between the wall connection and the side cushions 7.

Inflatable corner cushions are optionally 8 available (as standard for DOBO versions). These offer an even better sealing to the lorry. As they have no contact with the docking lorry in home position, they are less susceptible to wear.

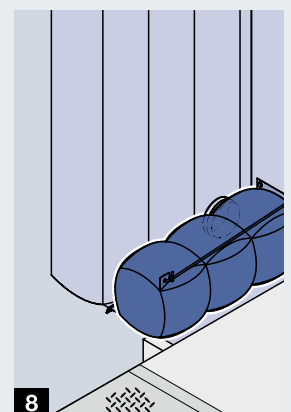
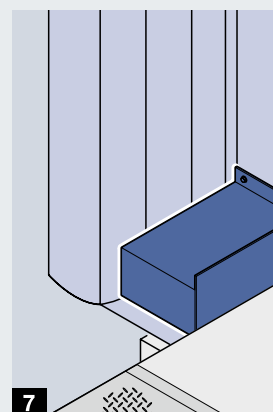

Inflatable dock seals

Versions and equipment options

1 Dock shelter DAS 3: dock model

Only after the lorry has docked does the blower inflate the dock seal around the vehicle, fully sealing the loading space within a few seconds. This dock shelter is particularly recommended for cold stores and extended loading times. The optional Crash Protection Bar **2** protects the frame construction from collision damage. This equipment is standard with the version with 1200 mm depth.

Standard size: 3600 × 3550 mm (W × H),
depth 850 mm, optionally 1200 mm
Inflated front opening: 2400 × 2550 mm (W × H)
Front opening in the home position:
3100 × 3150 mm (W × H)



3 Dock shelter DAS 3 DOBO: dock model

For the DOBO system, the dock shelter is made longer and fitted at the height of the recess for the movement of the vehicle doors. It is also equipped with inflatable corner cushions.

Standard size: 3600 × 3850 mm (W × H),
depth 850 mm, optionally 1200 mm
Inflated front opening: 2400 × 2850 mm (W × H)
Front opening in the home position:
3100 × 3450 mm (W × H)

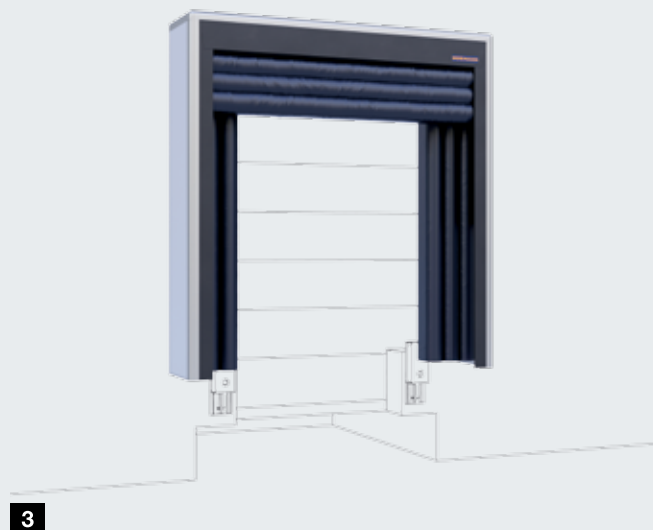

4 Dock shelter DAS-G3: roadway model

The roadway model allows unimpeded passage into the building with deflated cushions.

Standard size: 3600 × 4700 mm (W × H),
depth 850 mm
Inflated front opening: 2400 × 3700 mm (W × H)
Front opening in the home position:
3100 × 4300 mm (W × H)



5



**5 Dock shelter DAS 3-N:
Recess version**

Fitted in the recess, inflatable dock seals are particularly well protected against rainwater and snow loads.

Standard size: 3600 × 3550 mm (W × H)

Inflated front opening: 2400 × 2550 mm (W × H)

Front opening in the home position:

3100 × 3150 mm (W × H)

6



**6 Dock shelter DAS 3-L:
version for loading houses**

The recess version DAS3-L is intended for integration in a loading house with recess. The result is a visually appealing combination in which the dock shelter is optimally protected against rainwater and snow loads.

Standard size: 3600 × 3550 mm (W × H)

Inflated front opening: 2400 × 2550 mm (W × H)

Front opening in the home position:

3100 × 3150 mm (W × H)

7

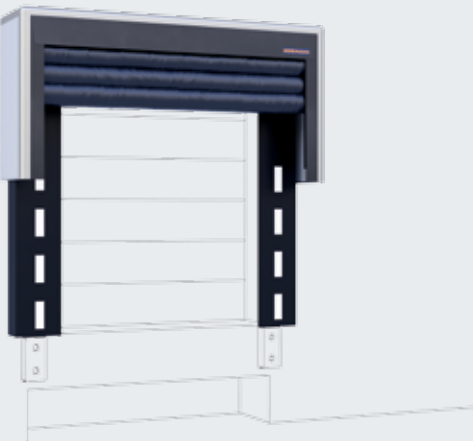

**7 Dock shelter DAK 3:
with fixed side cushions**

The DAK 3 is the advantageous combination of fixed side cushions and inflatable top cushion with cladding made of thermally insulated, 20-mm-thick steel panels. This dock shelter is particularly recommended for hanging goods with a standardised vehicle fleet. The foam-filled side cushions seal perfectly at the sides. On top the inflatable top cushions keep the loading opening completely free to directly forward the goods on conveyor systems.

Standard size:

3600 × 3500 × 350 / 850 mm (W × H × D)

with inflated top cushion: 2400 × 2500 mm (W × H)

Front opening in the home position:

2400 × 3100 mm (W × H)

Cushion dock seals

Versions and details

Cushion dock seals offer excellent sealing options for standardised vehicle dimensions. In addition to the fit, two other aspects are important during planning:

Cushion dock seals not only seal the transition from the rear of the lorry to the building, but also the air gap between the lorry and the open door. The lorry pushes into the cushion, making the cushions protrude into the loading opening. Cushion dock seals are therefore not suitable for lorries with top flap.

1 When docking, the cushions must not be pressed in more than 50 mm, so that they are not damaged by excessive compression pressure. Therefore it is important that the depth of the buffers has the right proportion to the depth of the cushions. The difference can be easily compensated by using buffer brackets. Consider the resulting increased distance between the vehicle and the ramp when choosing the lip length of a dock leveller, if necessary.

Cushions

The cushions are filled with PU foam. Together with the sturdy base frame and the high-quality cover made of textile-reinforced plastic flaps, the cushions form a durable unit.

The vertical cushions are either rectangular **2** or chamfered **3**. Angled cushions are a simple solution if the existing door is too wide.

Special shapes are also available **4** if required. With a slope of the roadway, for example, cushion designs with a compensating inclination are possible.

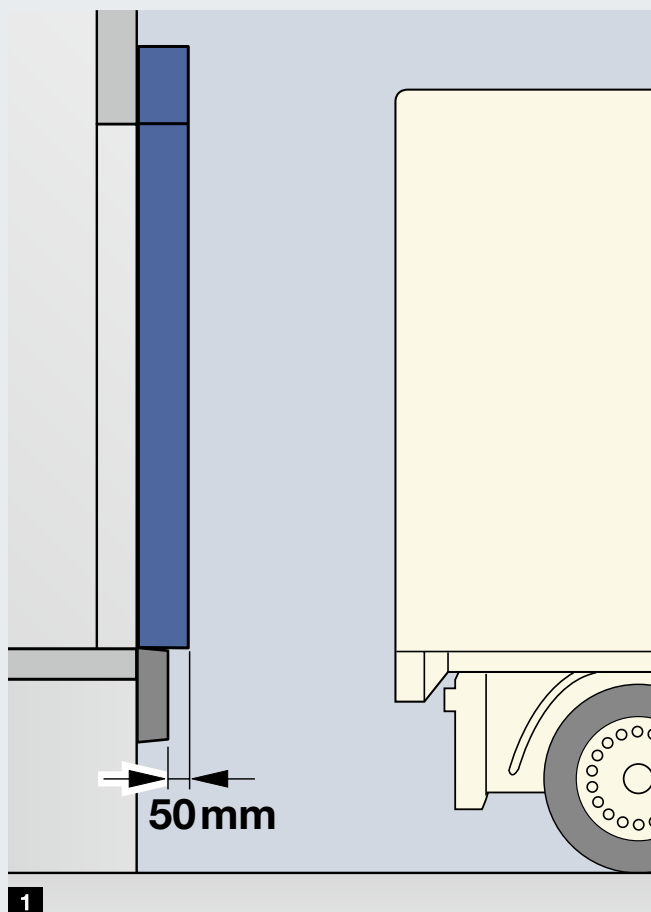

1

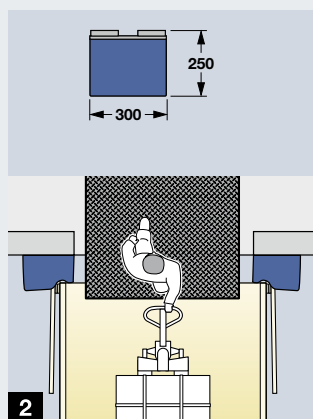

2

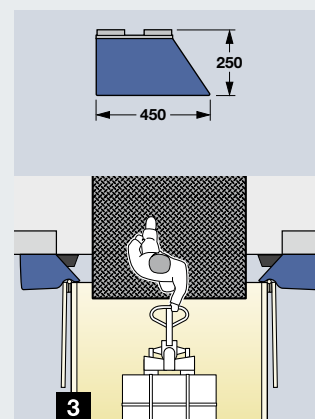

3

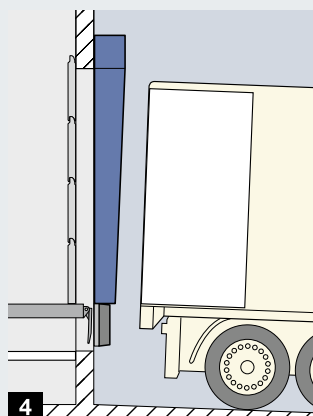

4

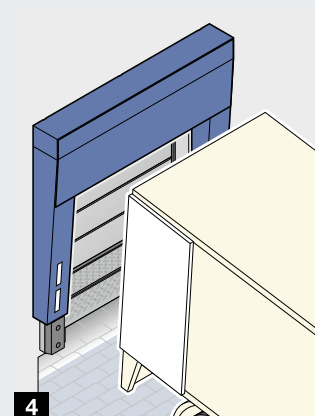

4



5

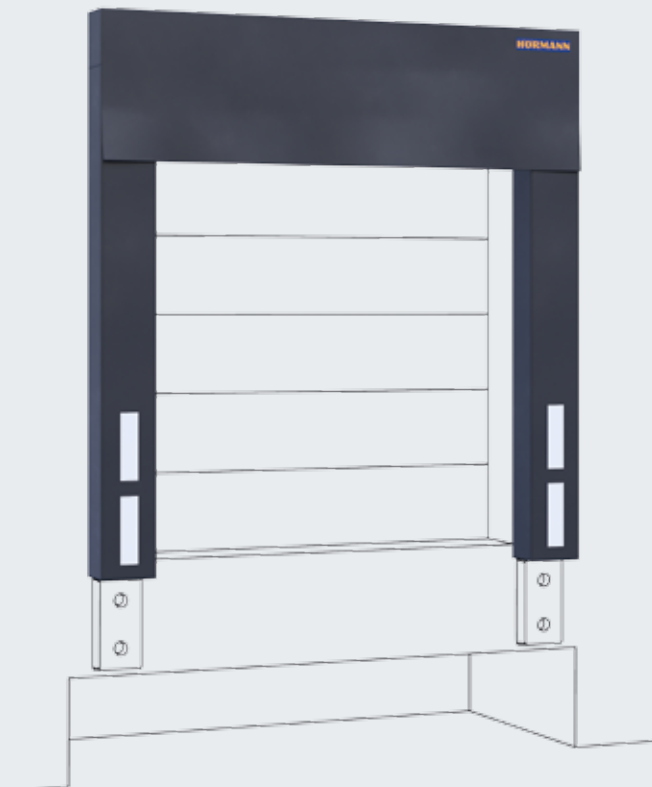

6

5 Type DFH

In this version with fixed side and top cushions, the lorry drives against the foam cushions for loading and unloading with doors already open.

Standard size: 2800 × 2500 × 250 mm (W × H × D)
 Front opening: 2200 × 2200 mm (W × H), with chamfered cushions 2040 or 1900 × 220 mm (W × H)

6 Type DFC

This dock shelter with fixed side cushions, top cushion with additional top flap is suitable for smaller lorries with different body heights and for buildings with high loading doors.

Standard size: 2800 × 3000 × 250 mm (W × H × D),
 front opening: 2200 × 2200 mm (W × H), with chamfered cushions 2040 or 1900 × 220 mm (W × H)



Graphite black, similar to RAL 9011



White

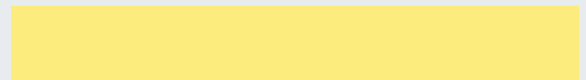

Yellow



Orange



Red

Colours

Cushions	
Graphite black, similar to RAL 9011	●
Marking stripes	
White	●
Yellow	○
Orange	○
Red	○

● = Standard
 ○ = Optional

Cushion dock seals BBS

Special solutions for parcel services and transit vans

The special rear shapes of small transport vehicles, e.g. parcel deliverers, require individual solutions. The cushion dock seal BBS was specifically developed to suit the rear shape of the Mercedes Sprinter (from year of manufacture 2006) and the equivalent VW Crafter (up to year of manufacture 2017). Of course, the BBS dock shelter is available for the current models and in other versions. Do you need an individual solution for your fleet? Please contact us.

1 The foam-filled cushions allow optimal sealing, both for hinged doors with 180° and 270° opening angle.

2 The top cushion has a recess for damage-free docking of vehicles with a rear camera. Depending on the position of the camera, the top cushion can be fitted with the recess facing down or up. The version without recess is also possible.

3 On request, the space between the ramp and the vehicle can be optimally sealed with the DUC bottom cushion.

As an alternative to the DUC lower cushion, the GD1 rubber ramp profile protects the ramp edge. The depth of 70–75 mm (depending on the type of fitting) provides enough space between the vehicle and GD1 to place the threshold profile of the mobile dock leveller.

4 For uncovered loading bays, the DWC protective cover is available.

Ordering size 1600 / 1970 × 2250 × 190 / 350 mm
(W × H × D)

Front opening 1200 / 1540 × 1800 mm (W × H)

Important:

Plan a ramp height of 650 mm to match the relatively low loading surface height.



If all ramps should be at the same height, adjusting the roadway level is a good solution to accommodate the different loading surface heights.



Take a look at the video “Dock shelter BBS” at: www.hoermann.com/mediacenter



Tip:

For vehicles with a rear step, we recommend a tailboard slot with low depth at the loading bay. A buffer, e.g. DB 15, is attached in the tailboard slot. Adjust the depth of the tailboard slot and bumper to the step. When the step reaches the buffer, the cushions of the dock shelter should not be pushed in more than 50 mm.

Buffers, fitting plates and support brackets

Product and planning advantages

Building and vehicle protection

Buffers are an indispensable part of the loading point. They protect buildings and vehicles from being damaged by the lorry's dynamic forces during docking. Selecting the right design version, correct dimensioning and proper positioning are essential for optimum effectiveness of the buffers.



Optimum positioning

Buffers must be positioned so that the lorry can reach them when docking. With the aid of buffer support brackets, the position of the buffers can be adapted to the individual requirements in order, for example, to allow a higher docking position.



Long-lasting design

The docking frequency of the vehicle fleet and the docking behaviour have a great impact on the service life of the buffers. For higher requirements, buffers made of PU or steel buffers are the right choice.



Application areas

The right buffer for any requirement

To protect against damages caused by docking forces

- Rubber buffers

For further information, please see page 66.



For an increased service life and higher docking frequency

- PU buffers
- Steel buffers

For further information, please see page 67.



For DOBO loading concepts

- Flexible buffers

For further information, please see page 69.



Buffers

Absorption and long service life

Rubber buffers

DB 15 **1**

This version is best suited to most loading points due to the size, depth and quality.

DB 15 XL **2**

This extra long buffer is designed to be fitted on a raised BCV XL support bracket and, depending on the design of the support bracket, also provides docking space 100 to 300 mm above ramp level.

DB 20 **3**

The slightly larger depth creates a greater distance between the vehicle and building. In addition, increased material thickness provides better absorption and durability.

Important:

When choosing a DB 20, check whether sufficient positioning depth for the lip of the dock leveller remains on the loading surface, especially for dock levellers with hinged lip.

VB 2 **4**

These buffers offer flexibility that protects your building. When vehicles remain docked close to the buffers, loading and unloading due to the lorry's movements creates forces that cause increased wear on the buffers. The VB 2 has two effects: it dampens the horizontal docking forces as a buffer and, with its vertical movement, lower the frictional forces of the moving lorry by moving parallel. The rubber buffer can slide up and down 100 mm vertical on a support bracket for this purpose.

DB 25 **5**

Buffers are ideal for loading points with dock shelter DAK 3.

DB 11 **6**

For small vehicles or as collision protection on and in the building, buffers of this size are recommended. We do not recommend these versions for docking lorries.

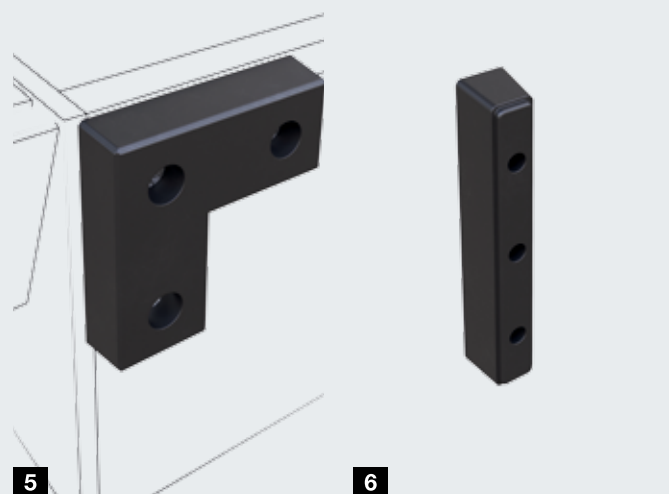
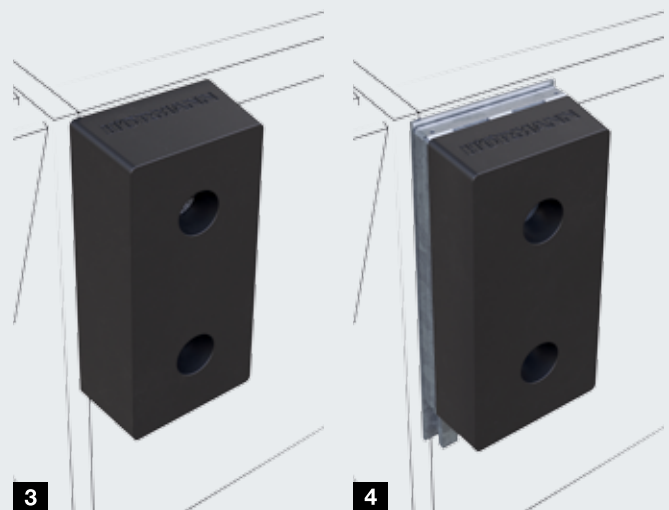
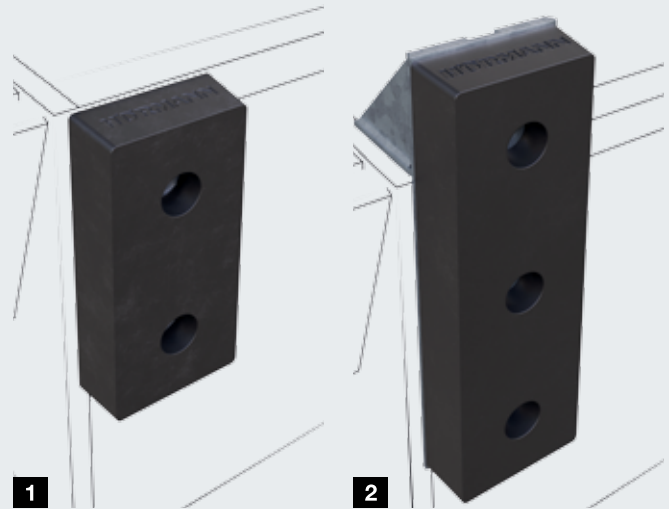

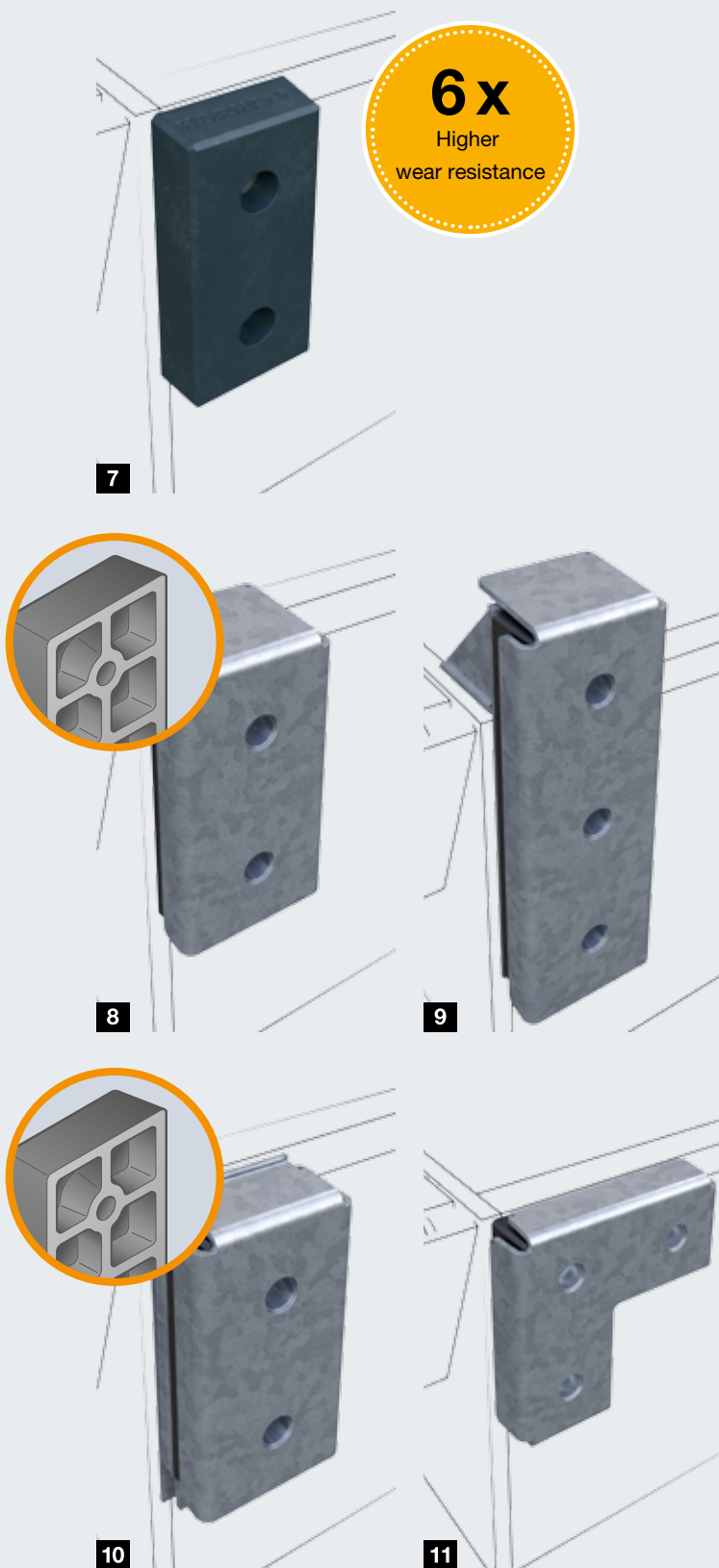

PU buffers

DB 15 PU **7**

This version has the same dimensions as the rubber DB 15, but is much more resistant to wear. The DB 15 PU is 6 times more resistant to abrasion according to ISO 4649 than a rubber buffer.

Steel buffers

SB 15 and SB 20 **8**

Where buffers are subjected to extreme stress and conventional buffers are destroyed too quickly, Hörmann steel buffers with full-surface absorption are the right choice. The angle protection plate on the buffer distributes the force from the approaching lorry evenly over the entire surface of the buffer and effectively protects it from wear. The special feature of the SB 15 and SB 20: Behind the steel plate, a so-called "Octabuffer" with eight air chambers ensures very good absorbing properties.

SB 15 XL **9**

The extra long combination of solid rubber buffer and steel angle protection plate is, like the DB 15 XL, designed to be fitted on a raised BCV XL support bracket and, depending on the design of the support bracket, also provides docking space of up to 300 mm above ramp level. Important: The building structure must be sufficiently statically dimensioned, continuous and, above all, exactly right-angled in order to be able to transfer the docking forces properly.

SBM **10**

This steel buffer can slide up and down 100 mm vertical on a support bracket, like the VB 2.

SB 25 **11**

Steel buffers are also available in angled form. Note that with this version, the full-rubber buffers behind the steel plate deform less and therefore greater force is transferred into the building structure. For this reason, the building must be sufficiently statically dimensioned.

Mounting plates and mounting brackets

For optimum fastening of buffers on the building

Mounting plates

1 BMP DB, 250 x 500 mm for buffers DB 15 (PU), DB 20, SB 15, SB 20

Mounting plates are recommended for optimum fastening of buffers on new constructions. But they are also suitable for renovation, e.g. if damage has occurred to the building.

2 BMPS DB, 195 x 500 mm for buffers DB 15 (PU), DB 20, SB 15, SB 20

This version is the optimal solution if the edge bracket of the dock leveller frame is positioned on the building structure. The 5-mm-thick mounting plate is fitted next to the edge bracket and thus prevents the acceleration forces from being transferred to the base frame.

Mounting brackets

3 BCH for buffers DB 15 (PU), DB 20, SB 15, SB 20

The space between the building and vehicle increases with the BCH. It is available in various depths and is often used in conjunction with loading flaps. In combination with cushion dock seals, they ensure that the cushions are not pushed in excessively. If the slope is inclined towards the building and the door opening is small, a greater distance may be needed to prevent the lorry from hitting the top of the building. Make sure there is sufficient support for the lip or sufficient lip length of the dock leveller!

On request, we also deliver special versions, e.g. to create a safety zone between the ramp and vehicle.

4 BCV and BCV XL for buffers DB 15 (PU), DB 20, SB 15, SB 20 as well as DB 15 XL, SB 15 XL

The buffer can be positioned higher with the BCV support bracket. The flush connection to both contact surfaces of the building structure and a reliable fixing are particularly important here, so that the building structure does not break away. Preferably use rubber buffers.

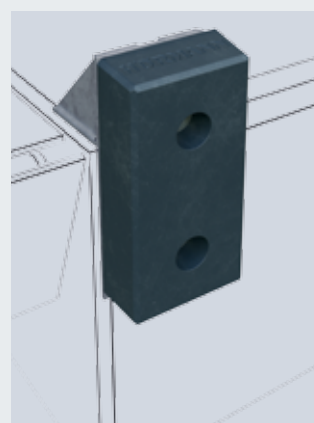
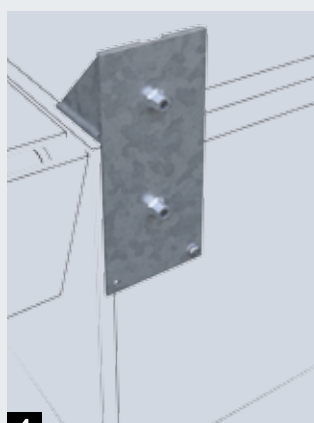
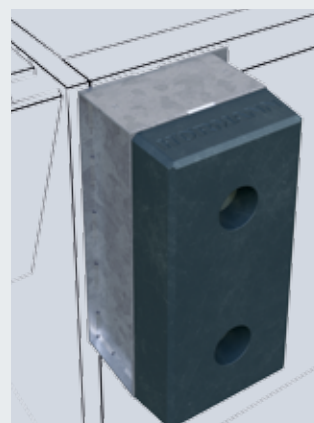
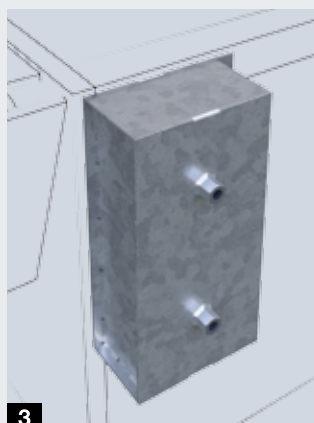
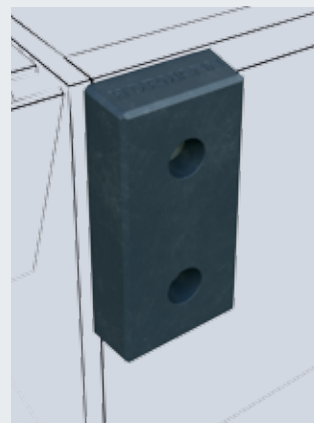
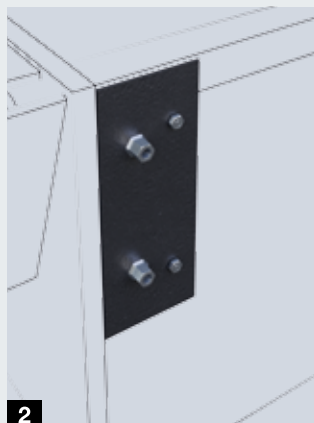
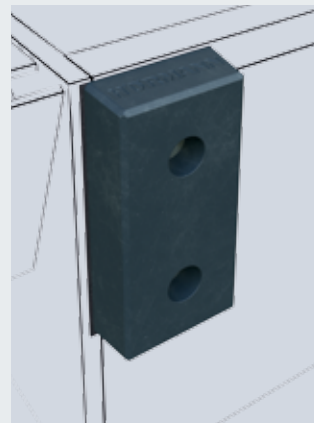
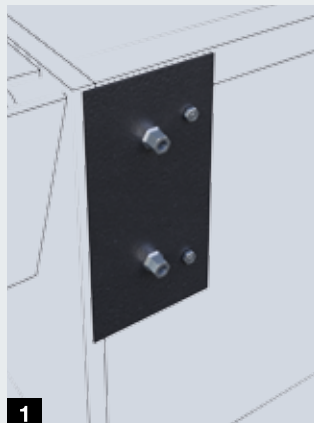

Flexible buffers

With large area of travel



VBV5 with sideways shifting support bracket and automatic release



Buffers

VBV4 1

The PU buffer is spring-loaded movable on the sideways shifting support bracket. It is at the standard level when docking and can then be pressed down to a lower level and locked so that the lorry doors can be opened. The VBV4 is exclusively used with the DOBO system, see page 38 – 41. In addition to the buffer and the support bracket, the scope of delivery also includes a handle for a secure stand when the buffer is pressed down.

VBV5 2

The patented VBV5 system consists of 2 PU buffers on a sliding support bracket with electronically assisted gas spring hydraulics and 2 handles. Similar to the VBV4, the buffer is spring-loaded movable on the sideways shifting support bracket. However, the VBV5 has an automatic release: As soon as the door is closed, the buffer springs back into the starting position. This always guarantees the correct position during docking. The advantage over fully automated systems: There are no unexpected buffer movements with the door open.

The VBV5 can be used as a spring buffer and for approaching above ramp level. The VBV5 is also particularly suitable for the DOBO system, see page 38 – 41.

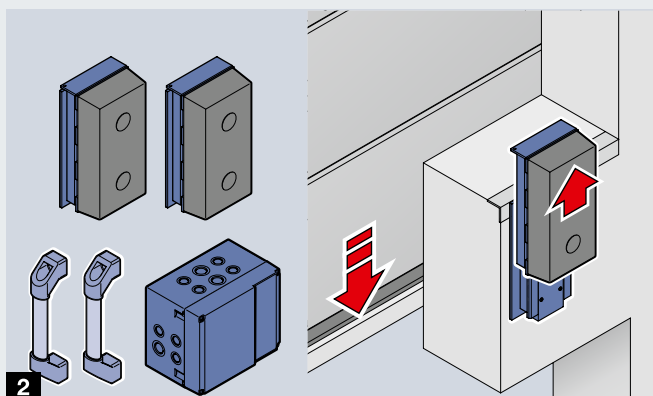
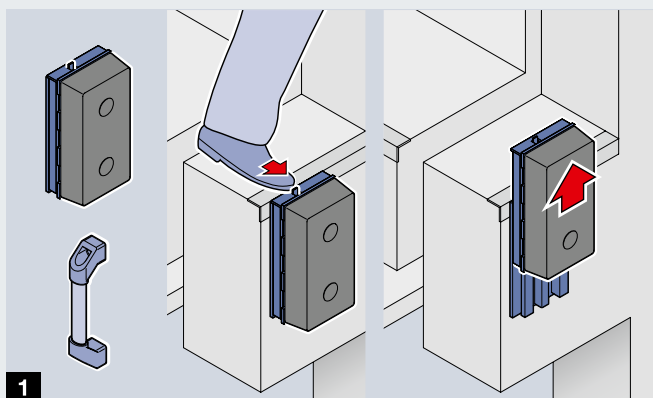

Buffers

Product range

The range of Hörmann buffers is as compact as it is high-quality and has the right solution for every requirement.

The buffers, fitting plates and support brackets are suitable for docking forces up to 100 kN.

Buffers	DB 11	DB 15	DB 15 XL	DB 20	VB 2	DB 25	
Spring / absorption	★	★★★	★★★	★★★★	★★★	★★★	
Service life	★	★★★	★★★	★★★	★★★★	★★★	
Investment costs	★	★★	★★	★★	★★★★	★★	

Legend: ★ low to ★★★★★ high

Buffers	DB 11	DB 15	DB 15 XL	DB 20	VB 2	DB 25	
Dimensions	80 x 490 x 90	250 x 500 x 100	250 x 750 x 100	250 x 500 x 140	250 x 595 x 149	450 / 180 x 100	
Rubber buffer	●	●	●	●	●	●	
PU buffer							
Steel buffer							
Suitable for loading platforms	For small vehicles	●	●	●	●	●	
Movable					●		
Docking above level		with BCV	with BCV XL	with BCV			
Suitable for the DOBO system							
Fitting on cast bolt sleeves in concrete		●		●	●	●	
Fitting with drill-in anchors on concrete	●	●	with BCV XL	●	●	●	
Fitting on steel pedestal		●	with BVC XL	●	●	●	
Fitting on fitting plate BMP / BMPS		●		●			
Suitable for fitting on BCH		●		●			

Horizontal buffer brackets	BCH
Support bracket depth	45 – 65 – 85 – 105 – 150 – 200 – 300 – 360 – 400 – 500 – 520
Fitting	exclusively on concrete

Vertical buffer brackets	BCV / BCV XL
Fitting height above pedestal level	100 – 120 – 150 – 200 – 250 – 300
Fitting	on concrete, pedestal

All dimensions in mm

	DB 15 PU	VBV4	VBV5	SB 15	SB 20	SB 15 XL	SBM	SB 25
	★★★★	★★★★	★★★★	★★★★	★★★★★	★★	★★★★	★★
	★★★★	★★★★	★★★★	★★★★★	★★★★★	★★★★★	★★★★★	★★★★★
	★★★	★★★★	★★★★★	★★★	★★★	★★★★	★★★★	★★★★

	DB 15 PU	VBV4	VBV5	SB 15	SB 20	SB 15 XL	SBM	SB 25
	250 × 500 × 100	250 × 682 × 165	250 × 682 × 195	277 × 518 × 112	277 × 518 × 152	277 × 768 × 112	277 × 610 × 161	490 / 220 × 490 / 220 × 115
	●	●	●					
				with octabuffer	with octabuffer	●	with octabuffer	●
	●	●	●	●	●	●	●	●
		●	●				●	
	with BCV	●	●	with BCV	with BCV	with BCV XL		
		●	●					
	●	●	●	●	●		●	●
	●	Chemical anchor	Chemical anchor	●	●		●	●
	●	●	●	●	●		●	●
	●			●	●			
	●			●	●			

Wheel chocks, drive-in aids and docking assistant

Product and planning advantages

Targeted and centred docking

Wheel guides or the Light Guide help the lorry driver during docking and prevent damage to the vehicle and ramp. They thereby ensure the functionality of the dock shelter and reduce ventilation heat losses.

For further information, please see page 74.



Securing vehicles against rolling away

Even when the lorry is well docked, its position can still change during loading, e.g. due to forklift braking when entering and exiting with the vehicle. We recommend the use of wheel chocks to avoid this and to prevent accidents.

For further information, please see page 75.



Controlled docking assistance

Electronic docking aids assist drivers in approaching the loading bay by using warning lights on the ramp. This results in safer, more precise docking by the driver and a substantial reduction in damage to the ramp and vehicle.

For further information, please see page 76.



Protection against collision damage

Robust protection bollards avoid expensive collision damage indoors and outdoors on doors or dock shelters.

For further information, please see page 77.



Safety with warning lights

Due to the lack of visual contact at the loading bay, communication between lorry drivers and warehouse personnel is limited. Interior and exterior warning lights provide visual information, e.g. that the lorry has reached the docking position and is secured.

For further information, please see page 77.



Bright work environment

There is usually insufficient additional illumination in the loading surface of the lorry. Docklights with a swivel arm ensure a well-lit loading surface, during both day and night. The loading process is much faster and damages to the transport goods are avoided.

For further information, please see page 77.



Wheel guides

Targeted and safe docking

Wheel guides

Wheel guides support the driver during centred docking at the loading point. Hörmann offers a wide range of options, such as wheel guides made of steel or even the optical Light Guide. A high and long wheel guide generally offers maximum guidance. Depending on the local conditions, it may be useful to resort to a smaller version.

The straight wheel guide **WSM 1** has a diameter of approx. 115 mm at a height of 220 mm.

More stability and a longer service life is offered by the **WBM 2** with a 170 mm diameter, 320 mm height and 3 fixing points. The curve guiding results in an entrance funnel.

Where a low height is crucial, e.g. when simply starting up and shutting down flatbeds, the **WBL 3** is the ideal choice, also in a curved version, but with a diameter of approx. 115 mm and a height of only 180 mm.

The **Light Guide 4** uses energy-saving LED technology to aid the approach to the ramp even in the dark or when visibility is impaired by precipitation.

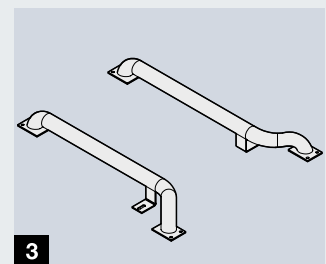
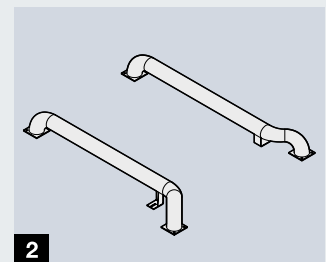
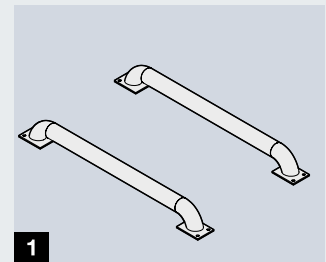

Wheel chocks

Workplace safety at loading points



Wheel chocks

Wheel chocks are the easiest way of securing the lorry against rolling away. Version **WR 1** is equipped with a 7 m long chain and a wall bracket for storage. Version **WRH 2** also has an operating bar for easier handling. For anyone who wants to ensure that the wheel chock is used properly, we recommend the version with a **WSPG 3** sensor. A sensor visually monitors contact with the tyres and prevents operation of the dock leveller without contact. An integrated position sensor additionally ensures that the wheel chock only emits the signal "lorry secured" if its base rests on the ground. The electronics are well protected against mechanical damage. The connection is provided with strain relief.

The WSPG can be connected in a variety of ways as needed:

- to any Hörmann dock leveller control
- to an operator control
- to a MWBC control, with or without docking assistant DAP.



Docking assistant DAP

Targeted and safe docking

Docking assistant systems carefully guide the lorry driver to the ramp by means of warning lights so that the driver can slow down the approach speed in a targeted manner, thereby protecting against collision damage.

Whereas the docking assistant HDA-Pro is only suitable for docking with closed lorry doors (DOBO systems in the building), the DAP system **1** can be used universally. For further information on the HDA-Pro see page 41.

DAP with DAPC control **2**

Depending on the requirement, the robust arm of the DAP system is equipped with one or two photocells, which detect the distance of the vehicle. When equipped with 2 photocells, the warning light first switches from green to yellow when approaching the ramp. The docking position is reached as soon as the warning light turns to red. Optionally, a warning light can be used to indicate that the door can be opened if there is no view from the inside to the outside. To ensure that the driver knows when he can safely leave the ramp after loading, he receives a green signal as soon as the door is closed again.

The switching range is adjustable. We recommend a switching range from green to yellow between 500 to 1000 mm in front of the ramp and to red between 50 to 100 mm.

The arm has a length of 500 mm; length of 1000 mm on request, e.g. for buffer brackets.

Alternatively or additionally, the DAP arm can be equipped with a 3-colour LED signal post green / yellow / red, 24 V.



DAP with MWBC control **3**

The DAP system in combination with the MWBC control offers numerous additional options such as:

- Optional: connection of a wheel chock with sensor
- Optional: connection of an inflatable dock seal for automatic on / off
- Status messages in the building via LED lights on the control
- Optional: connection of a signal horn for acoustic warning
- Release functions, e.g. so that the door can only be opened when the docking position is reached and secured.

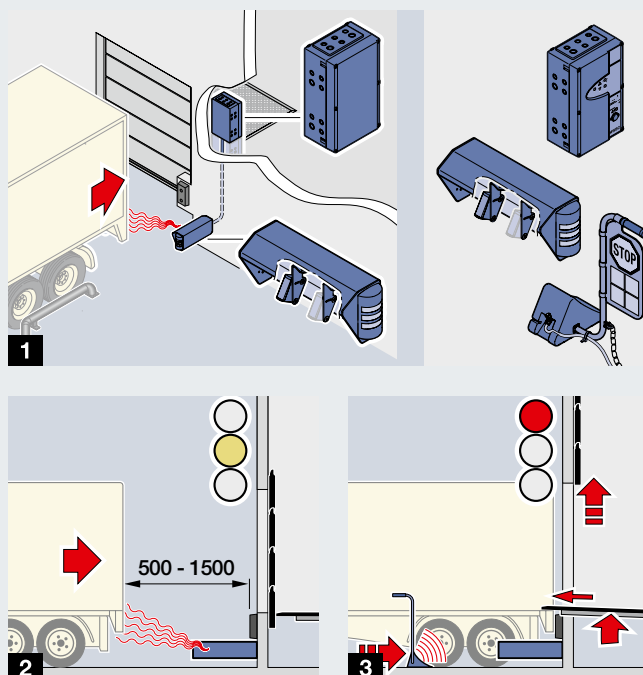

Protection bollards, warning lights and docklights

Workplace safety at loading points



Protection bollards 4

Protection bollards on the interior and exterior are a useful investment. They avoid expensive collision damage to driveway dock shelters or buildings.

LED warning lights 5

An additional optical control is provided by the combination with a signal system. Hörmann LED warning lights are energy-efficient, extremely durable and easily recognisable even in direct sunlight. Depending on the system, the driver can quickly see whether he has reached the docking position or whether the loading process is complete and he can drive away safely. Warning lights can be combined as needed with Hörmann operator controls, dock leveller controls 460 S / T and docking systems.



Docklight 6

Docklights provide a safe and bright work environment and good illumination of the loading surface. We recommend the energy-saving LED docklight DL 1400 with 30 W power consumption for a good and even illumination.



Hörmann Product Range

Everything from a single source for your construction project





Quick service with testing, maintenance and repairs
Our extensive service network means that we are always nearby and at your service around the clock.

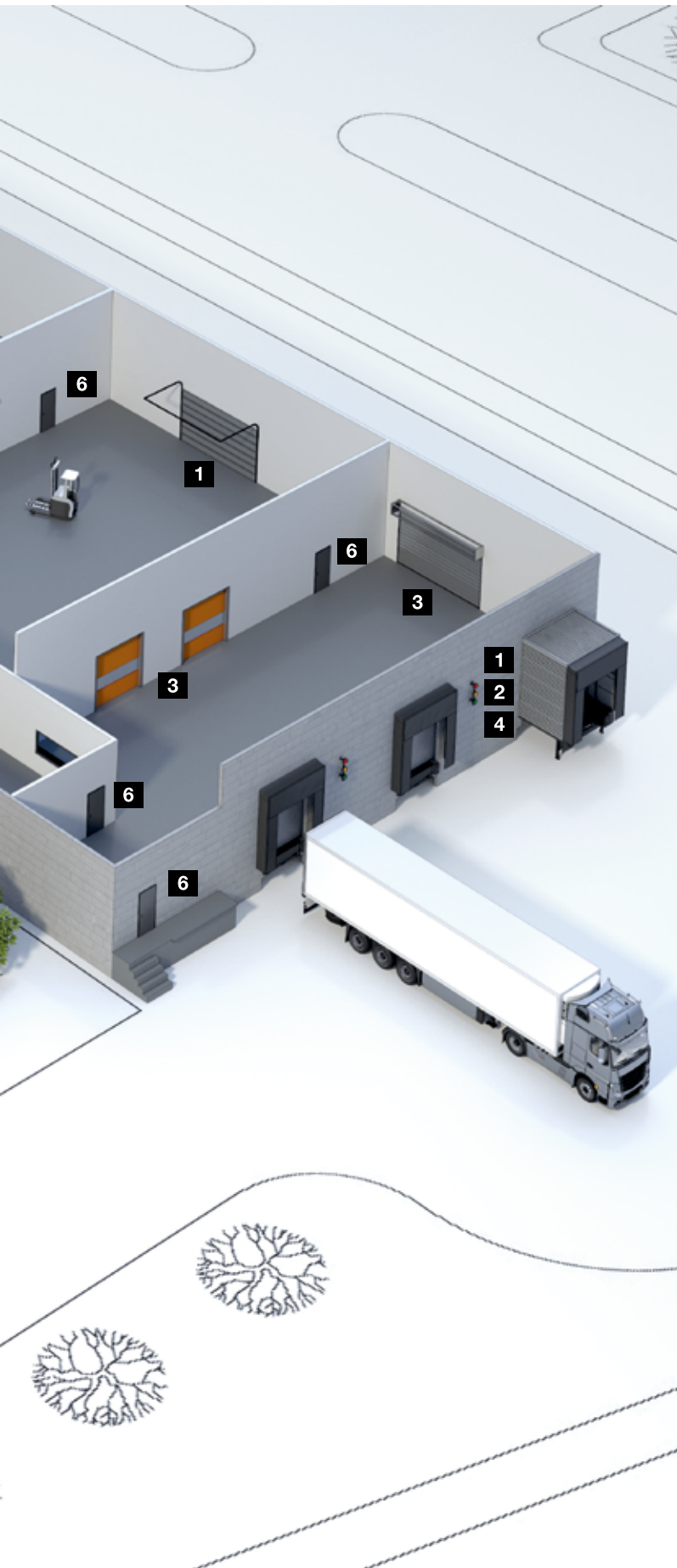

Sectional doors



Rolling shutters and rolling grilles



High-speed doors



Loading technology



Steel and stainless steel sliding doors



Steel and stainless steel construction project doors



Steel frames with high-quality timber function doors from Schörghuber



Tubular frame construction project doors



Automatic sliding doors

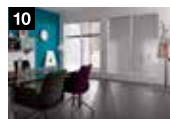

Visibility window



Collective garage doors



Bollards and road blockers



Barrier and pay station systems

Hörmann: Quality without Compromise



Hörmann KG Amshausen, Germany



Hörmann KG Antriebstechnik, Germany



Hörmann KG Brandis, Germany



Hörmann KG Brockhagen, Germany



Hörmann KG Dissen, Germany



Hörmann KG Eckelhausen, Germany



Hörmann KG Freisen, Germany



Hörmann KG Ichttershausen, Germany



Hörmann KG Werne, Germany



Hörmann Alkmaar B.V., Netherlands



Hörmann Legnica Sp. z o.o., Poland



Hörmann Beijing, China



Hörmann Tianjin, China



Hörmann LLC, Montgomery IL, USA



Hörmann Flexon LLC, Burgettstown PA, USA



Shakti Hörmann Pvt. Ltd., India

Hörmann is the only manufacturer worldwide that offers you a complete range of all major building products from one source. We manufacture in highly-specialised factories using the latest production technologies. The close-meshed network of sales and service companies throughout Europe, and activities in the USA and Asia, make Hörmann your strong partner for first-class building products, offering “Quality without Compromise”.

GARAGE DOORS
OPERATORS
INDUSTRIAL DOORS
LOADING EQUIPMENT
HINGED DOORS
DOOR FRAMES